



Drawing:
1 oz Imperial Round 20/410

Stock Code:
000100050200000

Manufacturing Process:
Injection Blow Molding

Overflow Capacity:
32 - 38 ml (1.1 - 1.3oz)

Gram Weight:
6.0 ± 0.5

Neck Finish:
20/410

Base Width (A):
1.160 ± 0.050

Overall Height (B):
2.930± 0.050

Max Print Area (Height):
1.625"

Max Print Area (Width):
3.437"

Case Pack: **1660**

Case Weight (lb): **24 ± 1.8**

Cases Per Pallet: **25**

Box Dimensions:
23 5/8 x 15 9/16 x 17

Stock Material:



CLASSIC CONTAINERS INC
1700 S. Hellman Ave.
Ontario, CA 91761
Phone: 909-930-3610
e-mail: info@classiccontainers.com
www.classiccontainers.com

FRONT VIEW

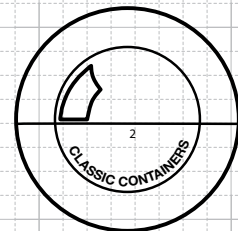
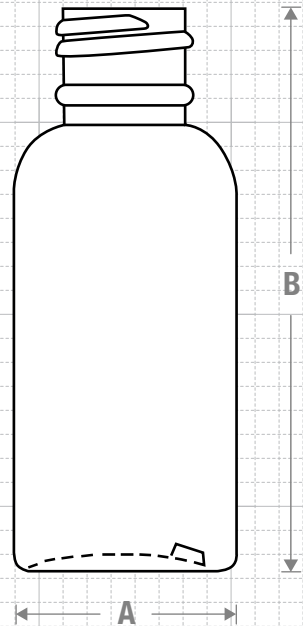

BOTTOM VIEW

NECK & THREAD DETAIL

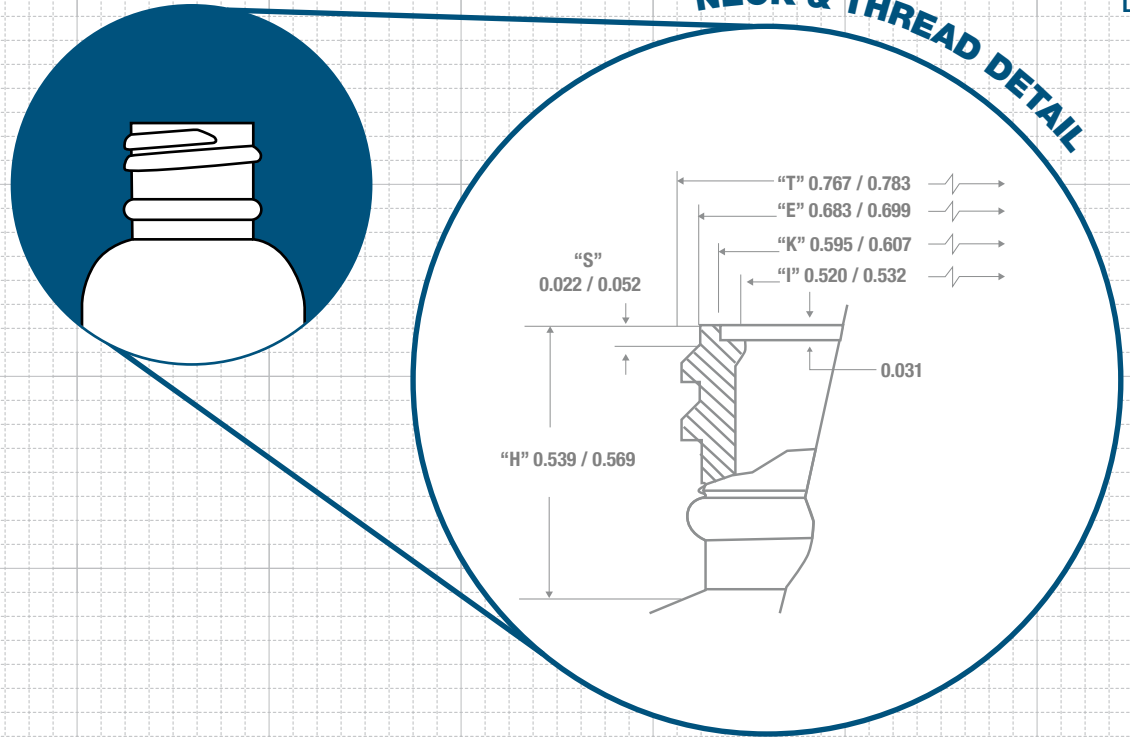

Recommended Plugs for this bottle



Recommended Plugs for this bottle



SNAP FIT

PRINTING SPECIFICATIONS: 1 oz IMPERIAL ROUND 20/410

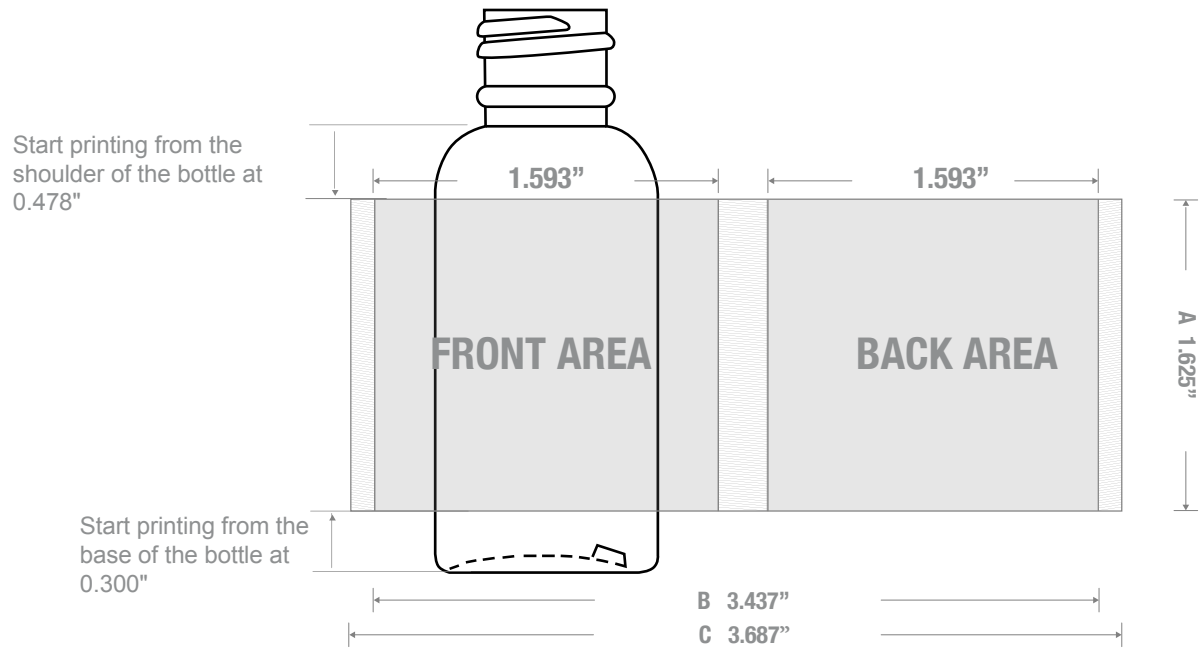

1700 S Hellman Ave, Ontario, California 91761
 Phone: (909) 930-3610 | Fax: (909) 930-3640
 e-mail: info@classiccontainers.com
www.classiccontainers.com

A - Total Height.
B - Max. Decorating Area.
C - Total bottle circumference.
 [Hatched Box] - Unprintable area.