



Drawing:
1 oz Evolution 20/410

Stock Code:
000100330200000

Manufacturing Process:
Extrusion Blow Molding

Overflow Capacity:
32.5 - 38.0 ml (1.1 - 1.3 oz)

Gram Weight:
6.5 ± 0.5

Neck Finish:
20/410

Base Width (A):
1.190 ± 0.050

Overall Height (B):
2.875 ± 0.050

Max Print Area (Height):
1.500"

Max Print Area (Width):
3.500"

Case Pack: 1710

Case Weight (lb): 26.6 ± 1.9

Cases Per Pallet: 25

Box Dimensions:
23 5/8 x 15 9/16 x 17

Stock Material:



CLASSIC CONTAINERS INC
1700 S. Hellman Ave.
Ontario, CA 91761
Phone: 909-930-3610
e-mail: info@classiccontainers.com
www.classiccontainers.com

FRONT VIEW

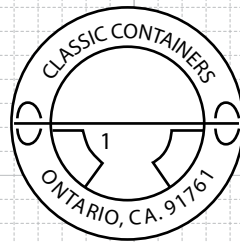
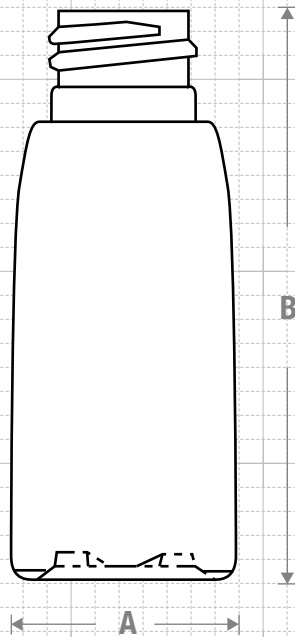

BOTTOM VIEW

NECK & THREAD DETAIL

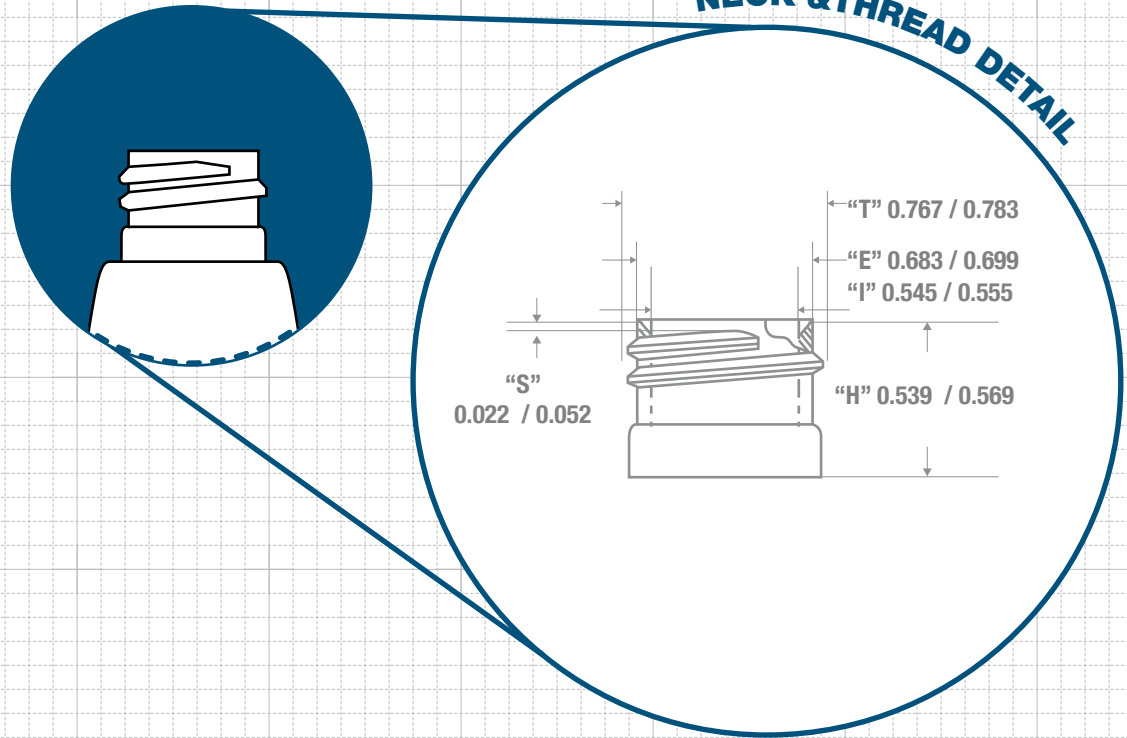

Recommended Plugs for this bottle



Recommended Plugs for this bottle



FRICITION FIT



PRINTING SPECIFICATIONS: 1 oz EVOLUTION 20/410

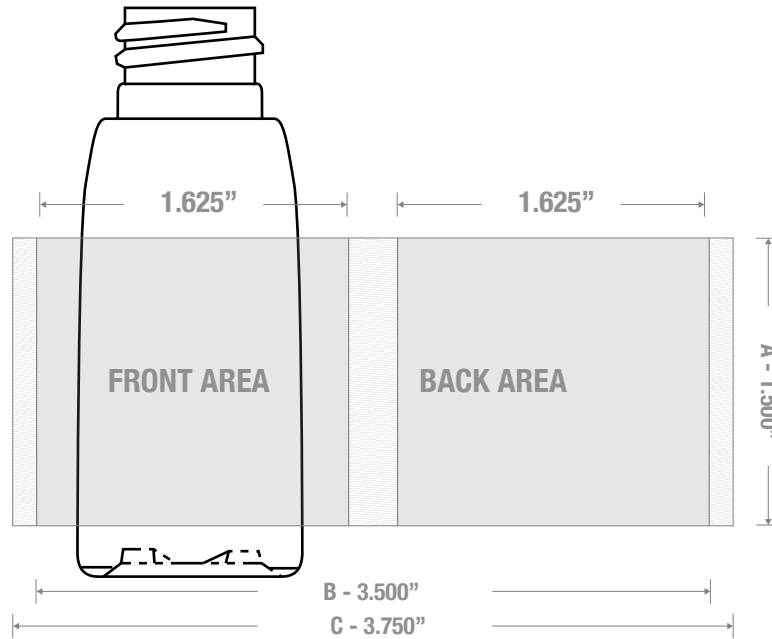

1700 S Hellman Ave, Ontario, California 91761
Phone: (909) 930-3610 | Fax: (909) 930-3640
e-mail: info@classiccontainers.com
www.classiccontainers.com

A - Total Height.
B - Max. Decorating Area.
C - Total bottle circumference.
▨ - Unprintable area.

LABELING SPECIFICATIONS: 1 oz EVOLUTION 20/410

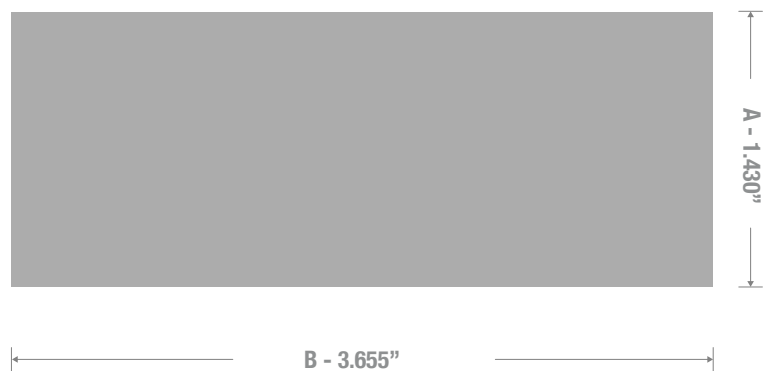

1700 S Hellman Ave, Ontario, California 91761
Phone: (909) 930-3610 | Fax: (909) 930-3640
e-mail: info@classiccontainers.com
www.classiccontainers.com

A - Total Height.
B - Total bottle circumference.