



Drawing:
1 oz Cylinder Round Classic
20/410 M-2

Stock Code:

Manufacturing Process:
Extrusion Blow Molding

Overflow Capacity:
32 - 38 ml (1.1 - 1.3 oz)

Gram Weight:
6.0 ± 0.5

Neck Finish:
20/410

Base Width (A):
1.160 ± 0.050

Overall Height (B):
2.785 ± 0.050

Max Print Area (Height):
1.730"

Max Print Area (Width):
3.375"

Case Pack: **1758**

Case Weight (lb): **25.4± 1.9**

Cases Per Pallet: **25**

Box Dimensions:
23 5/8 x15 9/16 x17

Stock Material:



CLASSIC CONTAINERS INC
 1700 S. Hellman Ave.
 Ontario, CA 91761
 Phone: 909-930-3610
 e-mail: info@classiccontainers.com
 www.classiccontainers.com

FRONT VIEW

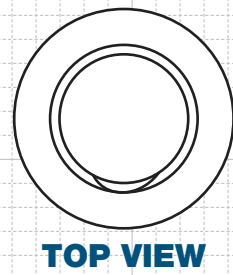
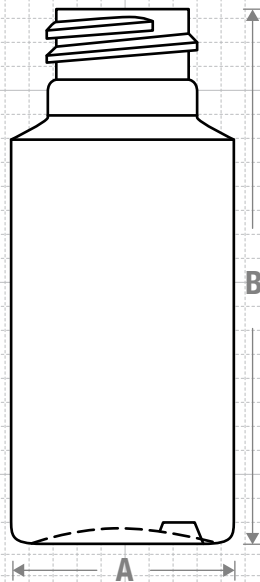

TOP VIEW

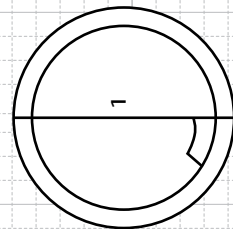

BOTTOM VIEW

NECK & THREAD DETAIL

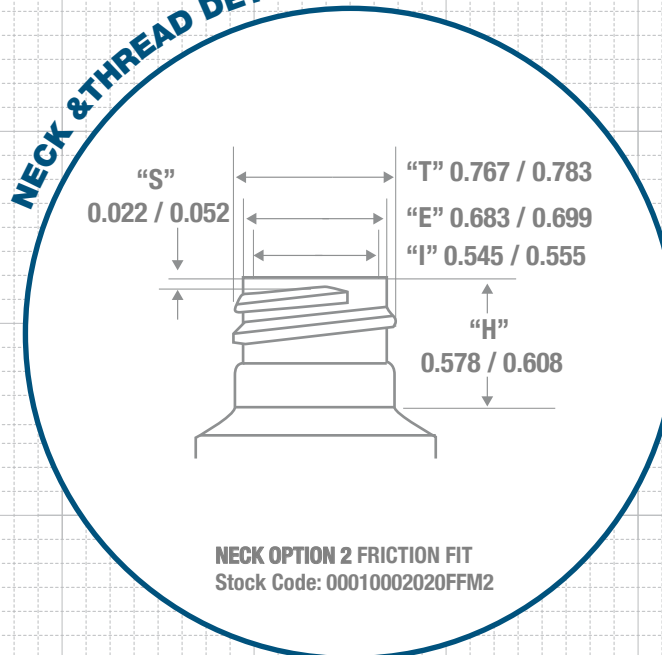

NECK OPTION 2 FRICTION FIT
 Stock Code: 00010002020FFM2

NECK & THREAD DETAIL

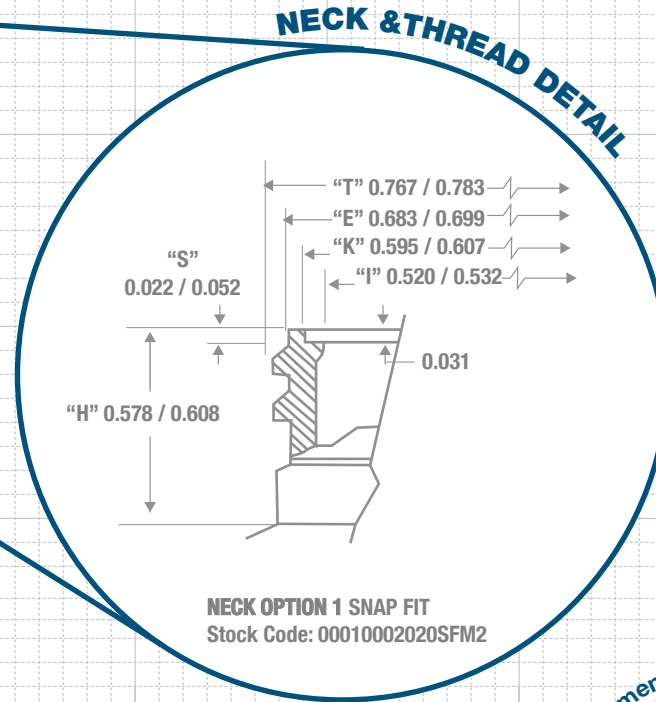

NECK OPTION 1 SNAP FIT
 Stock Code: 00010002020SFM2

Recommended Plugs for this bottle

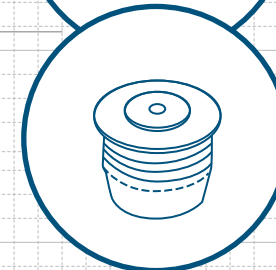

FRICTION FIT

Recommended Plugs for this bottle

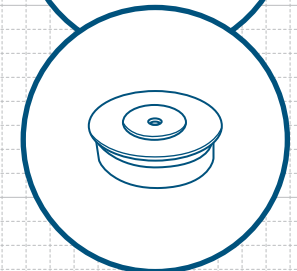
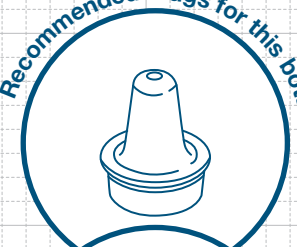

SNAP FIT



PRINTING SPECIFICATIONS: 1 OZ CYLINDER ROUND CLASSIC 20/410 M-2

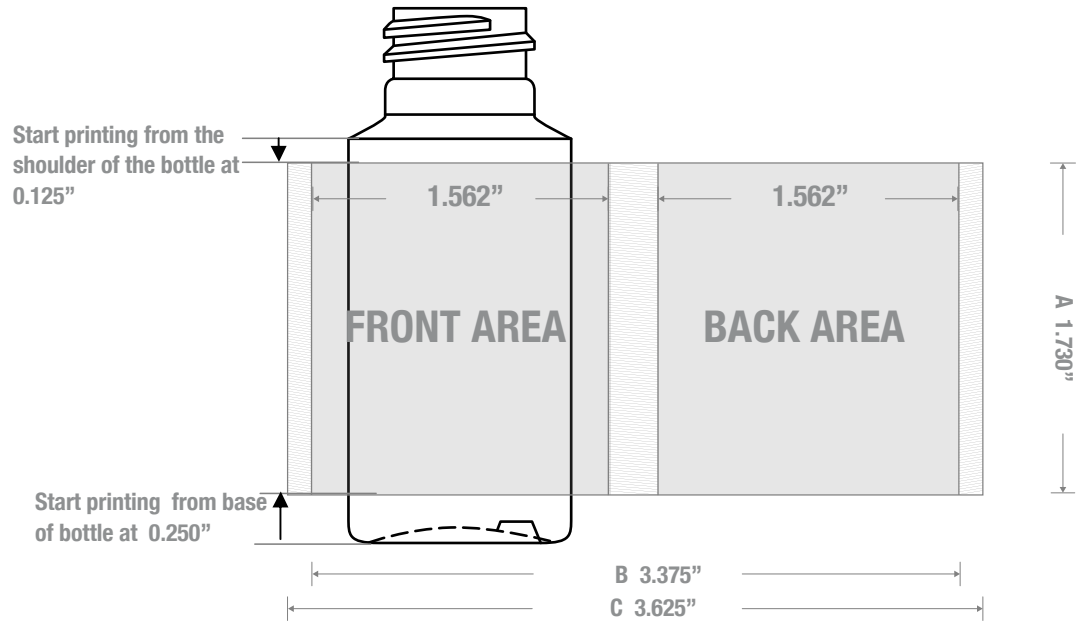

1700 S Hellman Ave, Ontario, California 91761
Phone: (909) 930-3610 | Fax: (909) 930-3640
e-mail: info@classiccontainers.com
www.classiccontainers.com

A - Total Height.
B - Max. Decorating Area.
C - Total bottle circumference.
☒ - Unprintable area.

LABELING SPECIFICATIONS: 1 OZ CYLINDER ROUND CLASSIC 20/410 M-2

LABELING AREA



1700 S Hellman Ave, Ontario, California 91761
Phone: (909) 930-3610 | Fax: (909) 930-3640
e-mail: info@classiccontainers.com
www.classiccontainers.com

A - Total Height.
B - Total bottle circumference.