



Drawing:
1 oz Classic Round 15/415

Stock Code:
000100230150000

Manufacturing Process:
Extrusion Blow Molding

Overflow Capacity:
30 - 33.9 ml (1.00 - 1.15 oz)

Gram Weight:
6.0 ± 1

Neck Finish:
15/415

Base Width (A): Base Depth (C)
1.253 ± 0.050 0.852 ± 0.03

Overall Height (B):
3.383 ± 0.050

Max Print Area (Height):
2.000"

Max Print Area (Width):
0.750"

Case Pack: 1840

Case Weight (lb): 26.4 ± 4.0

Cases Per Pallet: 25

Box Dimensions:
23 5/8 x 15 9/16 x 17

Stock Material:



CLASSIC CONTAINERS INC
1700 S. Hellman Ave.
Ontario, CA 91761
Phone: 909-930-3610
e-mail: info@classiccontainers.com
www.classiccontainers.com

FRONT VIEW

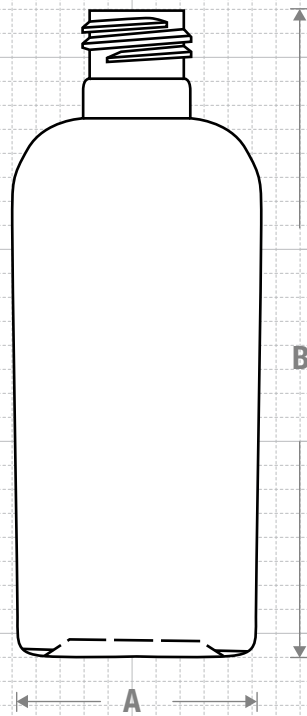

SIDE VIEW

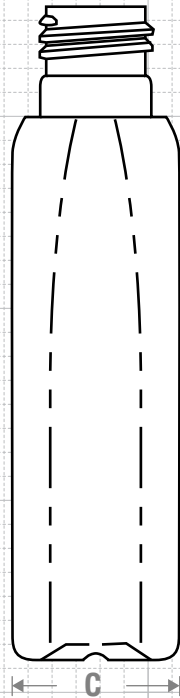

NECK & THREAD DETAIL

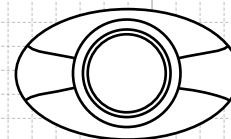
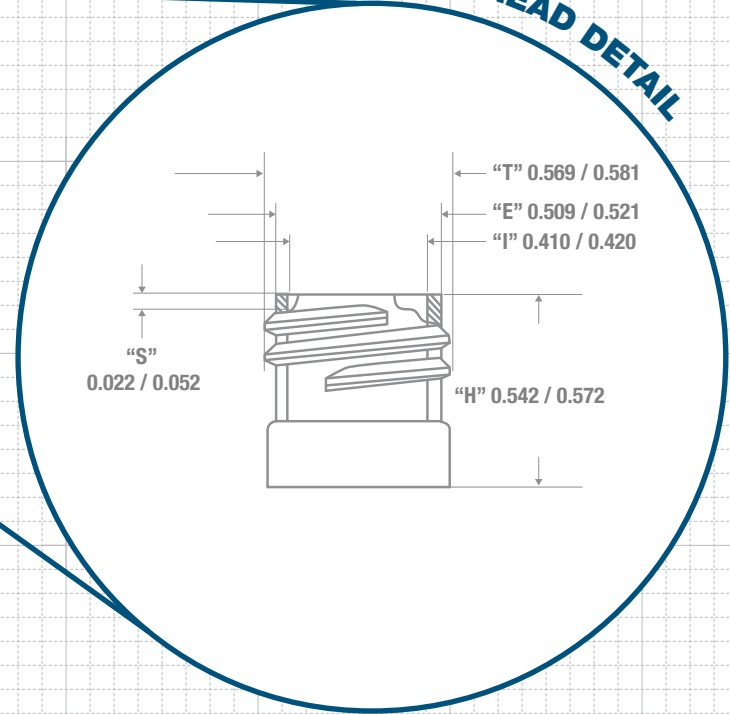

TOP VIEW



BOTTOM VIEW



PRINTING SPECIFICATIONS: 1 oz CLASSIC OVAL 15/415

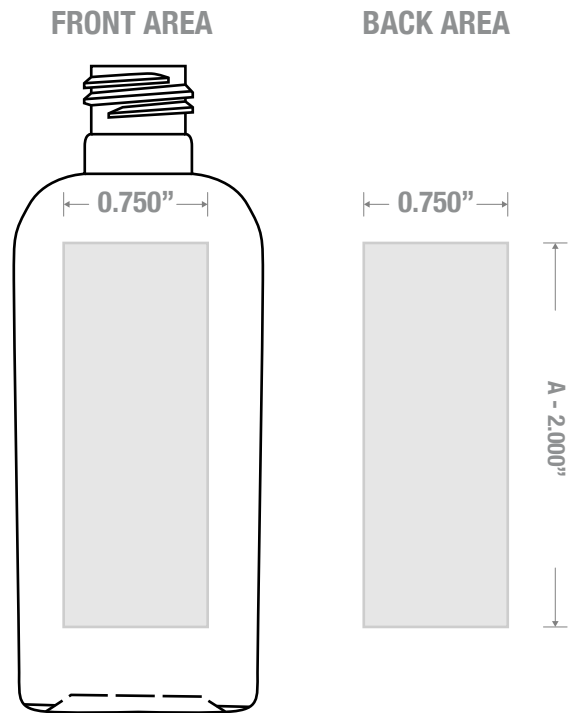

1700 S Hellman Ave, Ontario, California 91761
Phone: (909) 930-3610 | Fax: (909) 930-3640
e-mail: info@classiccontainers.com
www.classiccontainers.com

A - Total Height.
B - Max. Decorating Area.