

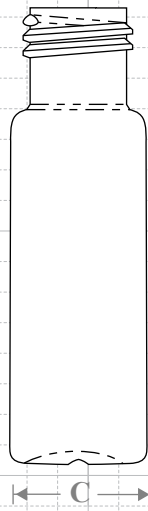

**FRONT VIEW**

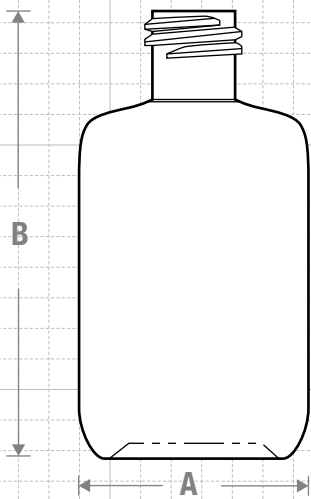

**NECK & THREAD DETAIL**

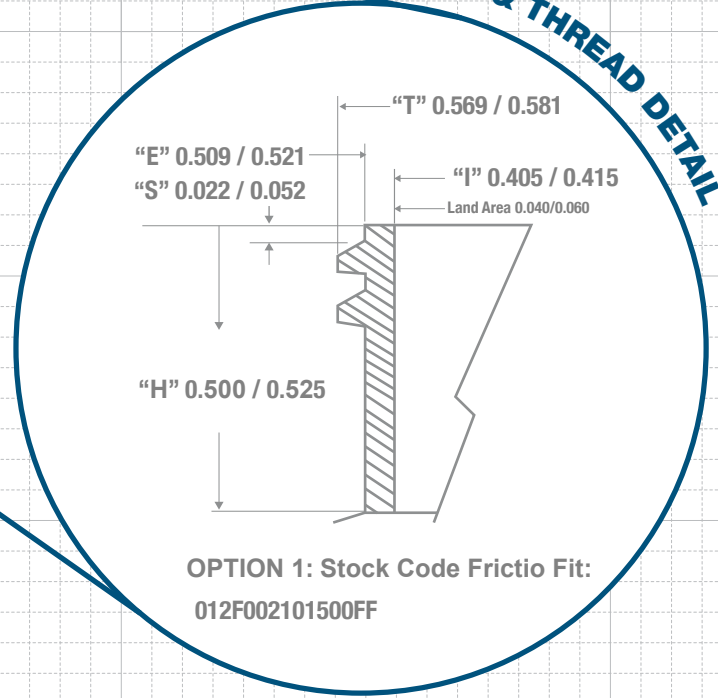

**SIDE VIEW**

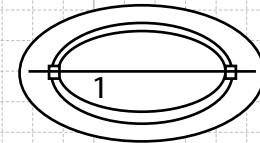

**BOTTOM VIEW**

**NECK & THREAD DETAIL**

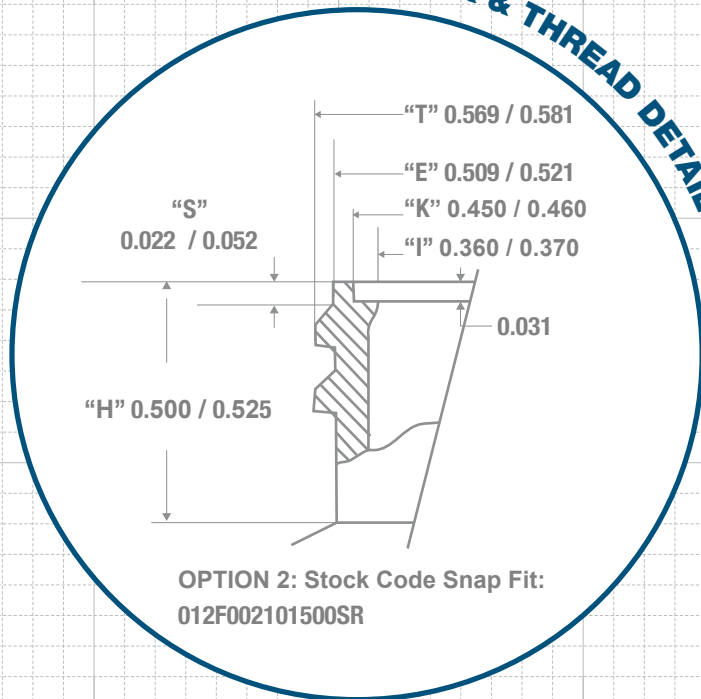

**DROPPER TIP CAP**



**SNAP FIT**



**CLASSIC CONTAINERS INC**  
1700 S. Hellman Ave.  
Ontario, CA 91761  
Phone: 909-930-3610  
e-mail: info@classiccontainers.com  
www.classiccontainers.com

Drawing:  
**1/2 oz Drug Oval 15/415**

Gram Weight:  
**4 ± 0.5**

Max Print Area (Height):  
**1.125"**

Cases Per Pallet: **20**

Stock Code:  
**1/2oz Drug Oval 15/415 Friction Fit:  
012F002101500FF**

Neck Finish:  
**15/415**

Max Print Area (Width):  
**0.875"**

Box Dimensions:  
**23<sup>5/8</sup> x 15<sup>9/16</sup> x 17**

**1/2oz Drug Oval 15/415 Snap Fit:  
012F002101500SR**

Manufacturing Process:  
**Extrusion Blow Molding**

Base Width (A): Base Deep (C)  
**1.274 ± 0.050 0.709 ± 0.050**

Case Pack: **2500**

Stock Material:



Overflow Capacity:  
**16.8 - 19.2 ml (0.57 - 0.65 oz)**

Overall Height (B):  
**2.390 ± 0.050**

Case Weight (lb): **24.2 ± 2.8**

Rev #5 - 08/2021

Drawing not exactly to size.

