



Drawing:
1/2 oz Boston Round 15/415

Stock Code:
012F00060150000

Manufacturing Process:
Injection Blow Molding

Overflow Capacity:
16.5 - 18.3 ml (0.56 - 0.62 oz)

Gram Weight:
4.5 ± 0.5

Neck Finish:
15/415

Base Width (A):
0.970 ± 0.050

Overall Height (B):
2.440 ± 0.050

Max Print Area (Height):
1.188"

Max Print Area (Width):
2.875"

Case Pack: 2450

Case Weight (lb): 26.2 ± 2.7

Cases Per Pallet: 20

Box Dimensions:
23 5/8X15 9/16X17

Stock Material:



CLASSIC CONTAINERS INC
1700 S. Hellman Ave.
Ontario, CA 91761
Phone: 909-930-3610
e-mail: info@classiccontainers.com
www.classiccontainers.com

FRONT VIEW

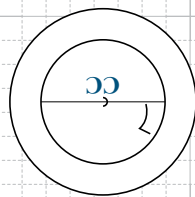
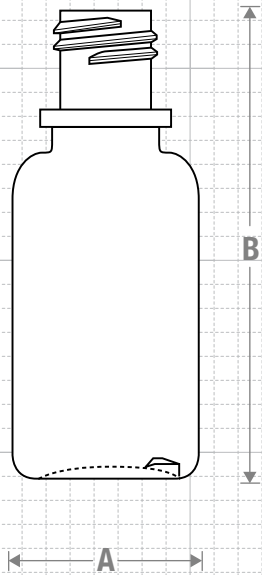

BOTTOM VIEW

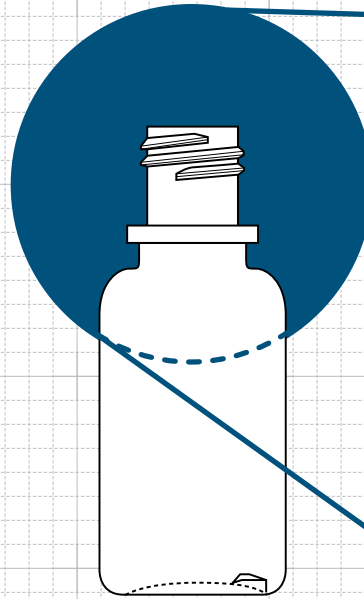

THREAD DETAIL

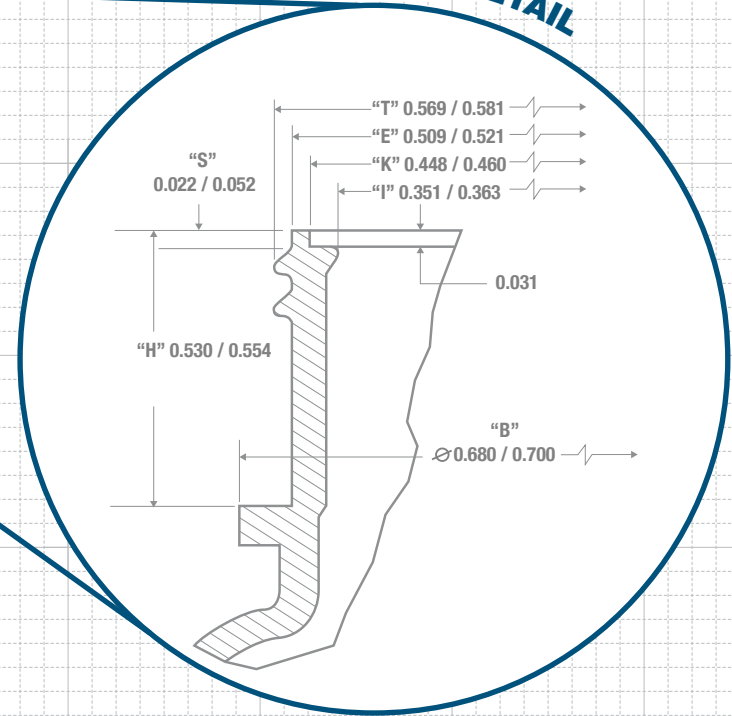

DROPPER TIP CAP

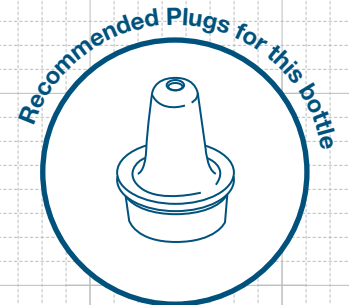

SNAP FIT



Other Material Options

Stock Material: **HD/PE**
Case Pack: **2600**
Case Weight (lb): **28 ± 2.9**

PRINTING SPECIFICATIONS: 1/2 oz BOSTON ROUND

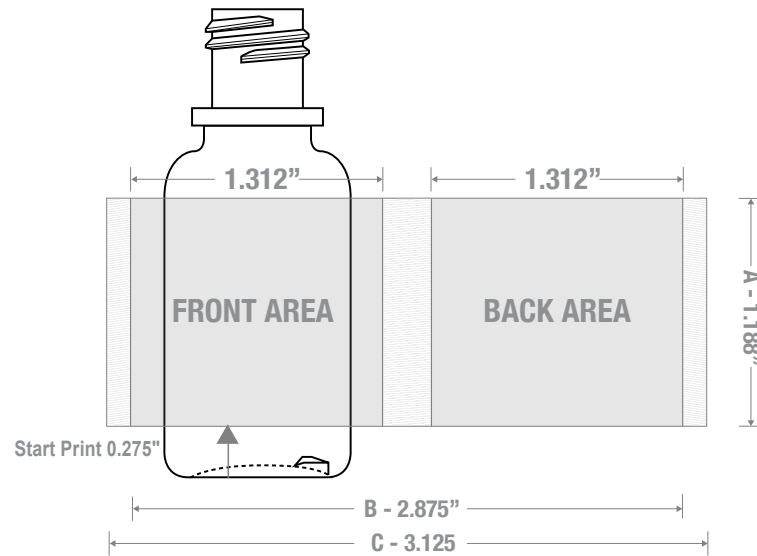

1700 S Hellman Ave, Ontario, California 91761
Phone: (909) 930-3610 | Fax: (909) 930-3640
e-mail: info@classiccontainers.com
www.classiccontainers.com

A - Total Height.
B - Max. Decorating Area.
C - Total bottle circumference.
▨ - Unprintable area.