

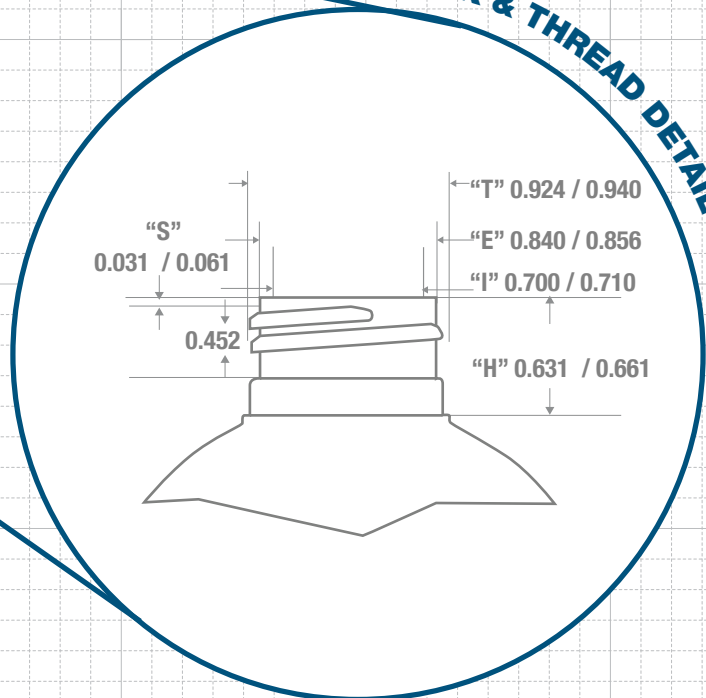

NECK & THREAD DETAIL

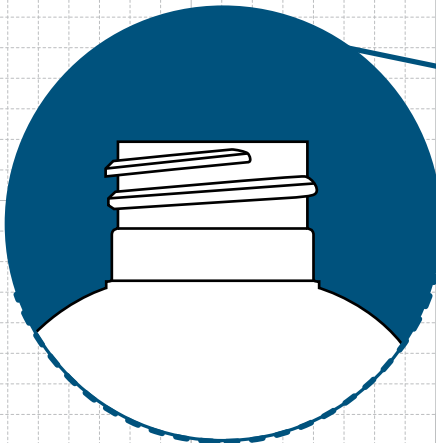

FRONT VIEW

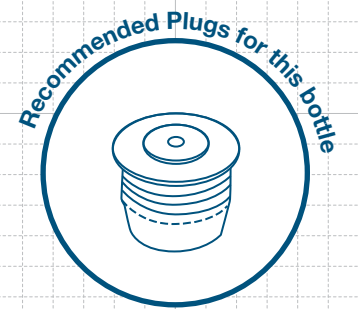
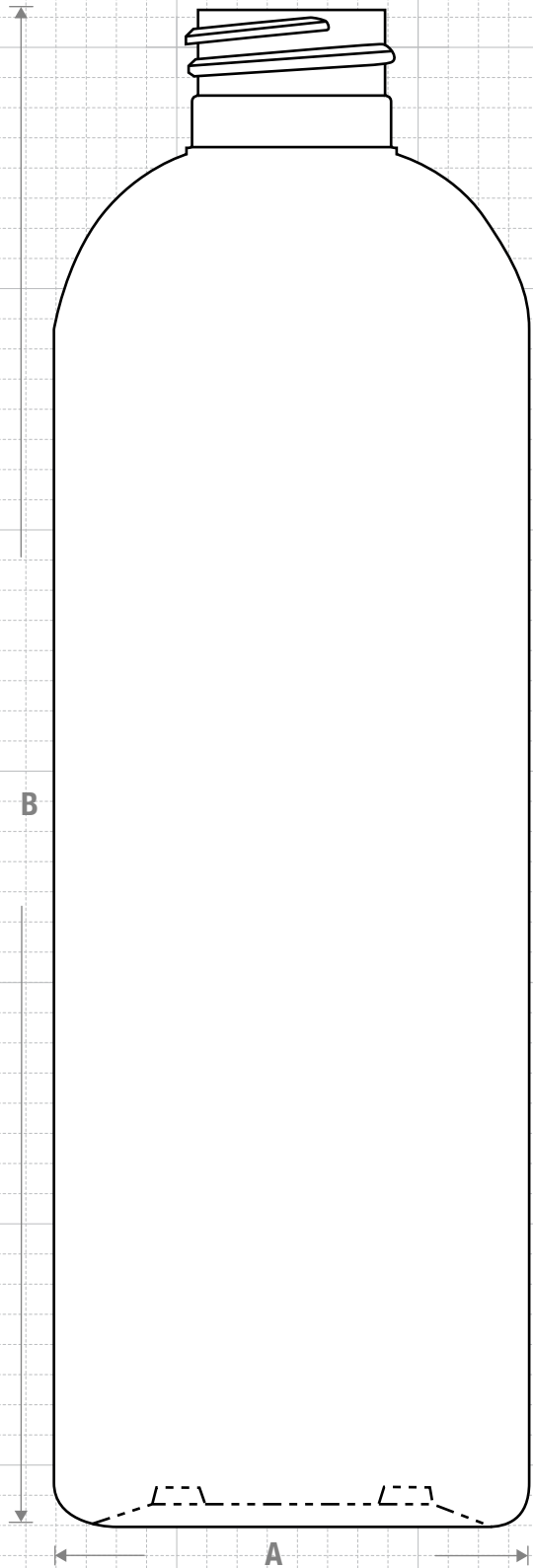

FRICITION FIT

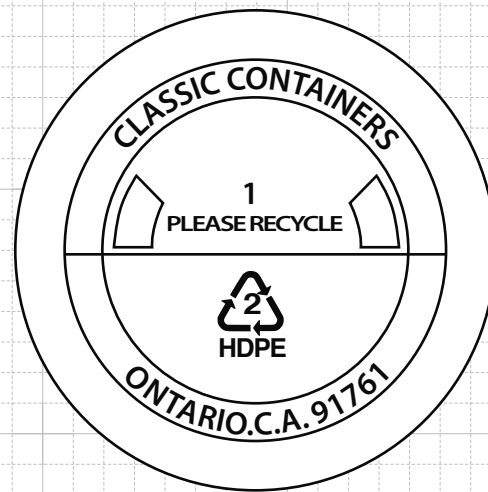

BOTTOM VIEW



CLASSIC CONTAINERS INC
1700 S. Hellman Ave.
Ontario, CA 91761
Phone: 909-930-3610
e-mail: info@classiccontainers.com
www.classiccontainers.com

Drawing:
17 oz Royalty Round 24/410

Gram Weight:
33.0 ± 2

Max Print Area (Height):
5.750"

Cases Per Pallet: **16**

Stock Code:
001700040240000

Neck Finish:
24/410

Max Print Area (Width):
7.625"

Box Dimensions:
24 7/16 x 18 1/2 x 23

Manufacturing Process:
Extrusion Blow Molding

Base Width (A):
2.500± 0.050

Case Pack: **231**

Stock Material:



Overflow Capacity:
513 -531 ml (17.4- 18.0 oz)

Overall Height (B):
7.915 ± 0.050

Case Weight (lb): **19.7 ± 1.0**

Rev #2 06/2016

Drawing not exactly to size.

