

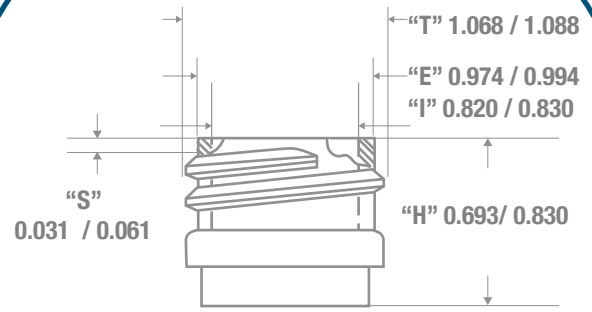

NECK & THREAD DETAIL

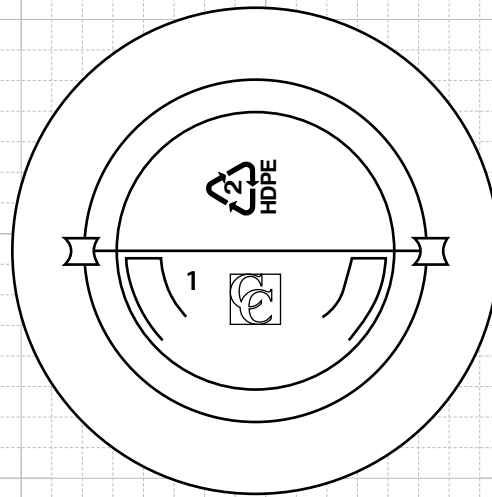

FRONT VIEW

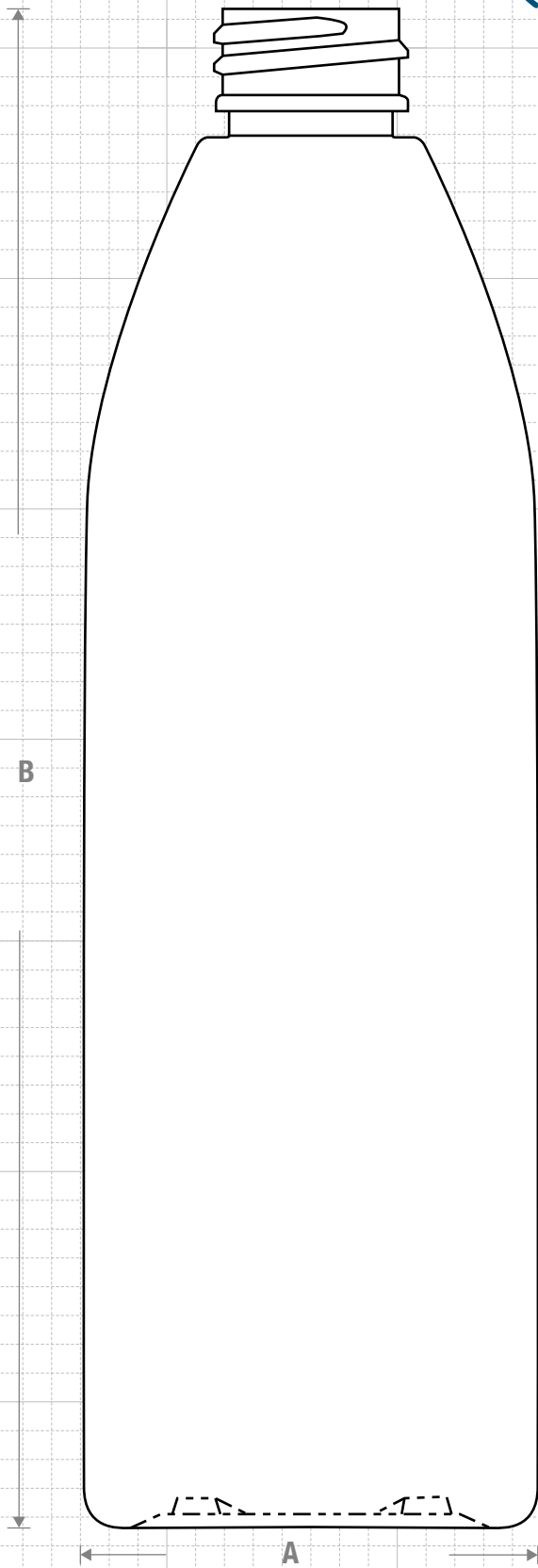

BOTTOM VIEW



Other Material Options

Stock Material: **SOFT T**
 Case Pack: **180**
 Case Weight (lb): **15.5 ± 0.8**



CLASSIC CONTAINERS INC
 1700 S. Hellman Ave.
 Ontario, CA 91761
 Phone: 909-930-3610
 e-mail: info@classiccontainers.com
 www.classiccontainers.com

Drawing:
16 oz Evolution 28/410

Gram Weight:
32 ± 2

Max Print Area (Height):
5.000"

Cases Per Pallet: **16**

Stock Code:
001600330280000

Neck Finish:
28/410

Max Print Area (Width):
7.750"

Box Dimensions:
24 7/16 x 18 1/2 x 23

Manufacturing Process:
Extrusion Blow Molding

Base Width (A):
2.532± 0.050

Case Pack: **194**

Stock Material:



Overflow Capacity:
528 - 552 ml (17.9 - 18.7 oz)

Overall Height (B):
8.363 ± 0.050

Case Weight (lb): **16.6 ± 0.8**

Rev #3 05/2015

Drawing not exactly to size.



1700 S Hellman Ave, Ontario, California 91761
Phone: (909) 930-3610 | Fax: (909) 930-3640
e-mail: info@classiccontainers.com
www.classiccontainers.com

A - Total Height.
B - Total bottle circumference.

