

**FRONT VIEW**

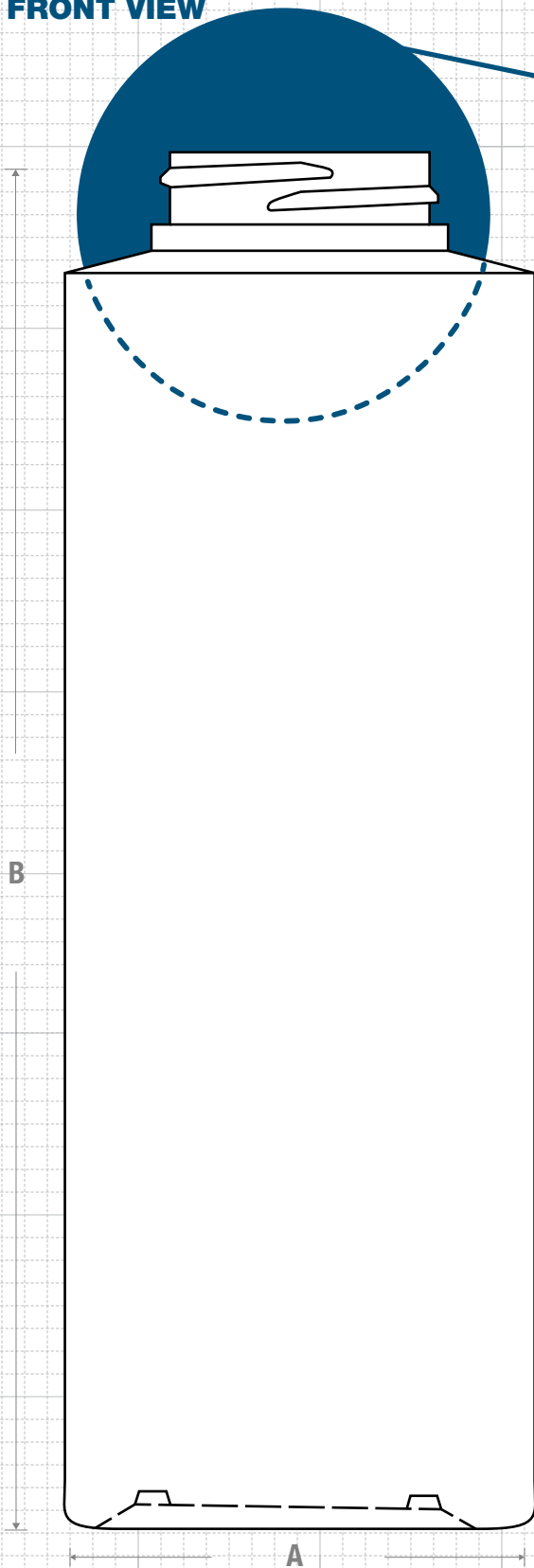

**NECK & THREAD DETAIL**

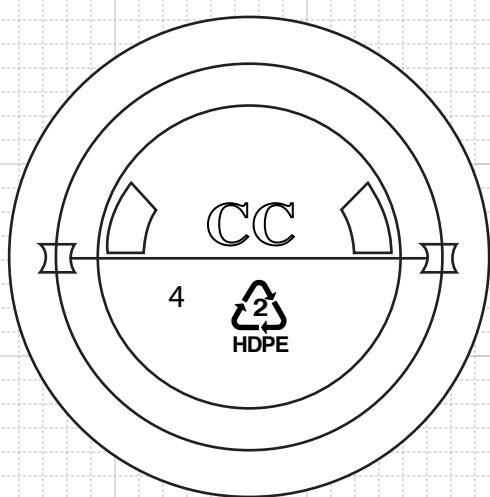
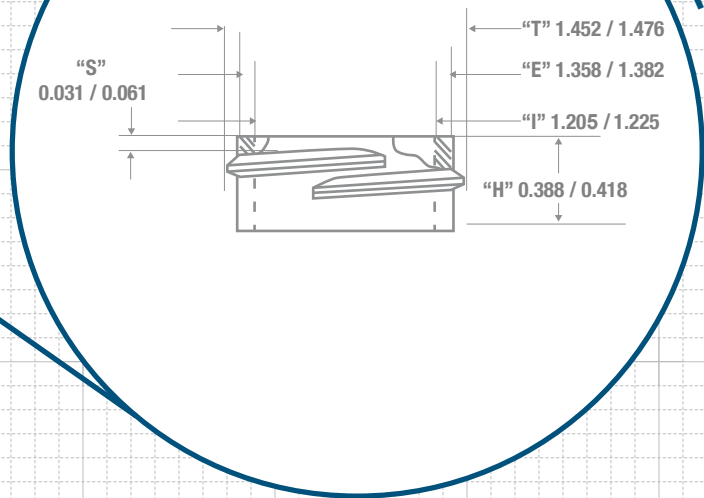

**BOTTOM VIEW**

- HDPE
- LDPE
- PP
- OTHER



**CLASSIC CONTAINERS INC**  
 1700 S. Hellman Ave.  
 Ontario, CA 91761  
 Phone: 909-930-3610  
 e-mail: info@classiccontainers.com  
 www.classiccontainers.com

Drawing: <b>16 oz Cylinder Round 38/400 With Step</b>	Gram Weight: <b>32 ± 2</b>	Max Print Area (Height): <b>6.375"</b>	Cases Per Pallet: <b>16</b>
Stock Code: <b>00160001038STEP</b>	Neck Finish: <b>38/400</b>	Max Print Area (Width): <b>7.500"</b>	Box Dimensions: <b>24 7/12 x 18 1/2 x 23</b>
Manufacturing Process: <b>Extrusion Blow Molding</b>	Base Width (A): <b>2.500 ± 0.050</b>	Case Pack: <b>231</b>	Stock Material:  HDPE
Overflow Capacity: <b>507 - 531 ml (17.2 - 18.0 oz)</b>	Overall Height (B): <b>7.500 ± 0.050</b>	Case Weight (lb): <b>19.2 ± 1</b>	Rev #4 - 11/2016 Drawing not exactly to size.

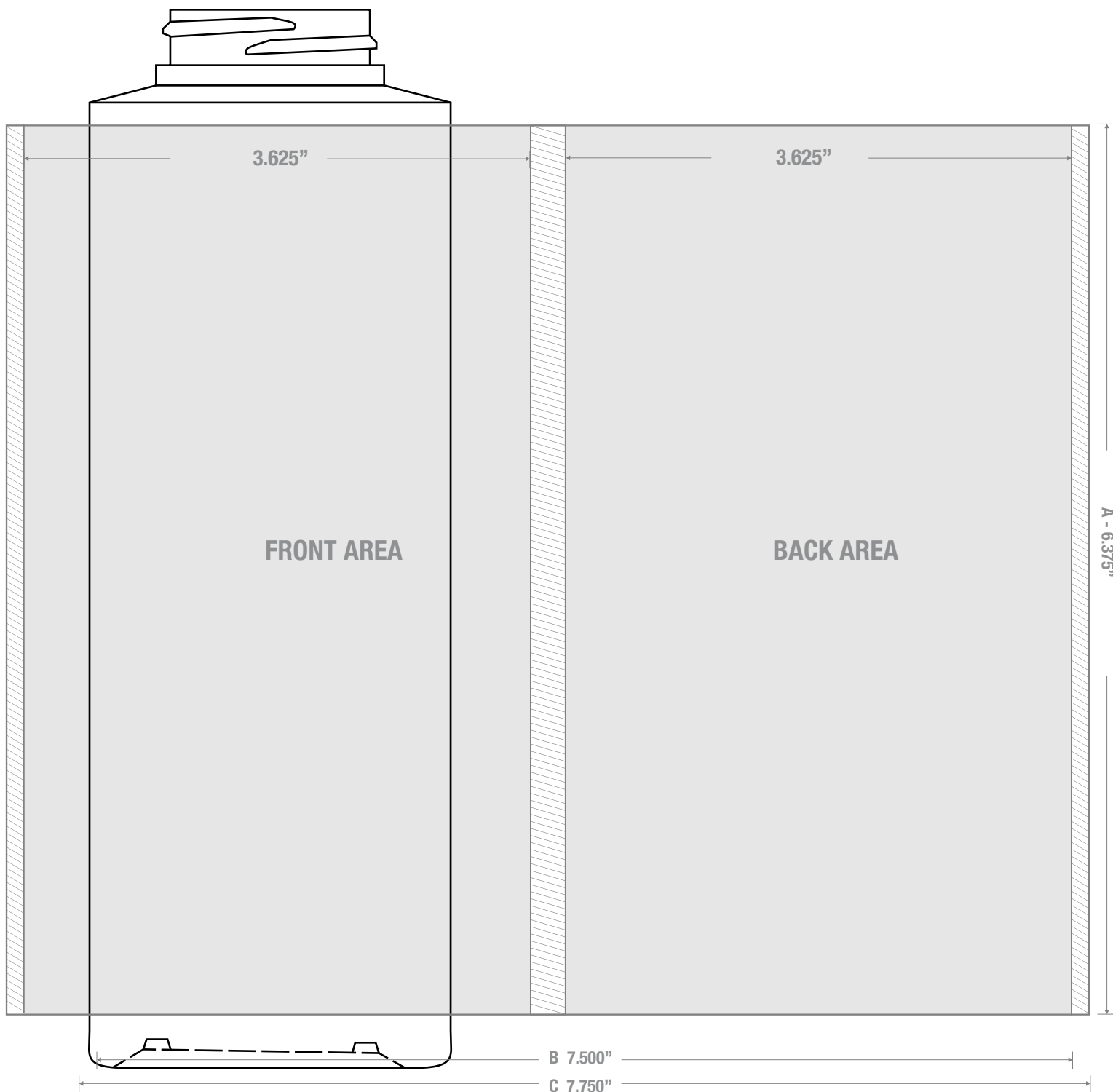

**LASSIC  
ONTAINERS  
Inc.**

1700 S Hellman Ave, Ontario, California 91761  
Phone: (909) 930-3610 | Fax: (909) 930-3640  
e-mail: [info@classiccontainers.com](mailto:info@classiccontainers.com)  
[www.classiccontainers.com](http://www.classiccontainers.com)

**A - Total Height.**  
**B - Max. Decorating Area.**  
**C - Total bottle circumference.**  
▨ - Unprintable area.

WRAP LABELING SPECIFICATIONS: 16 oz CYLINDER ROUND 38/400 with Step

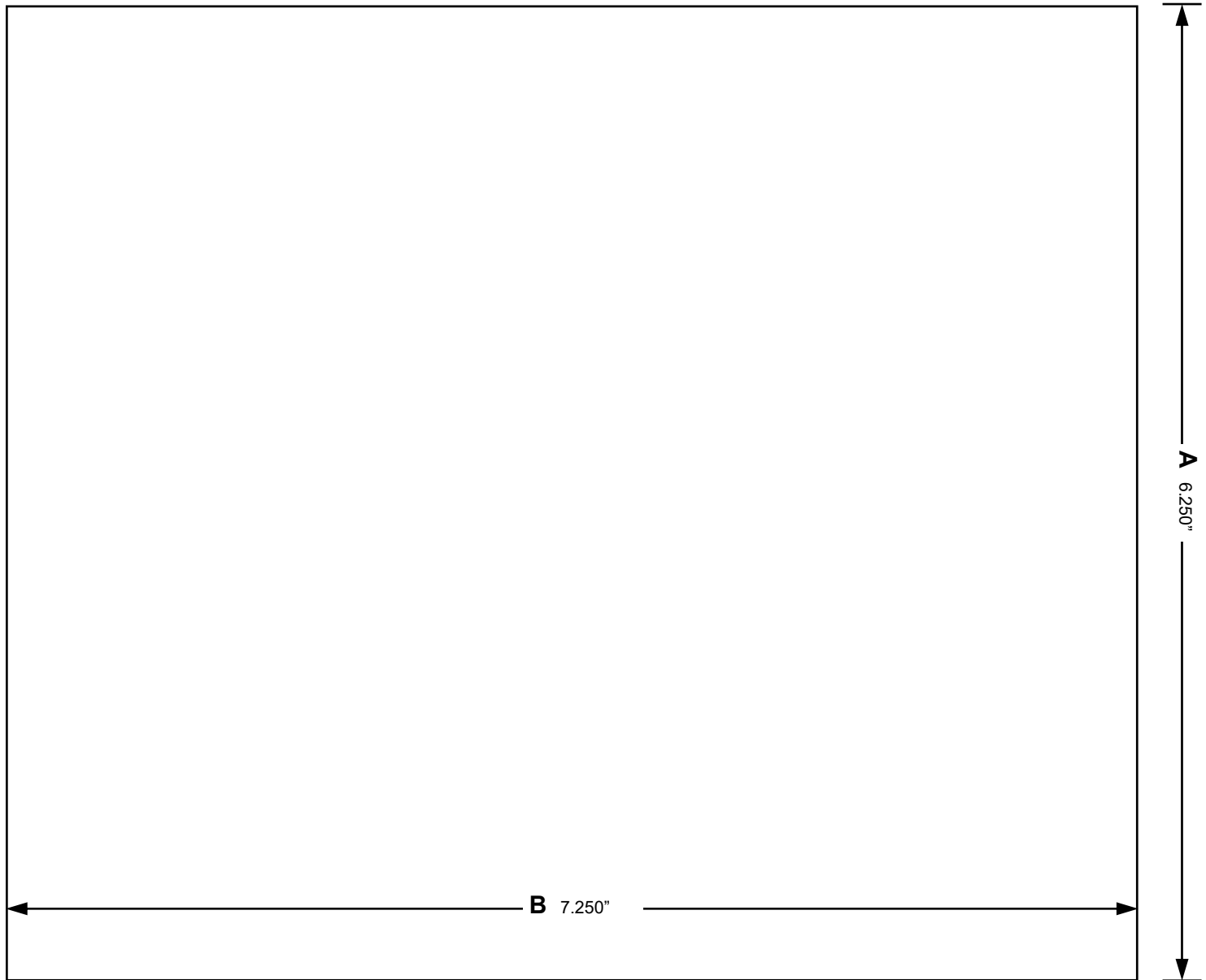

**Maximum Label Area**

*A - Total Height. B - Total Width*