

FRONT VIEW

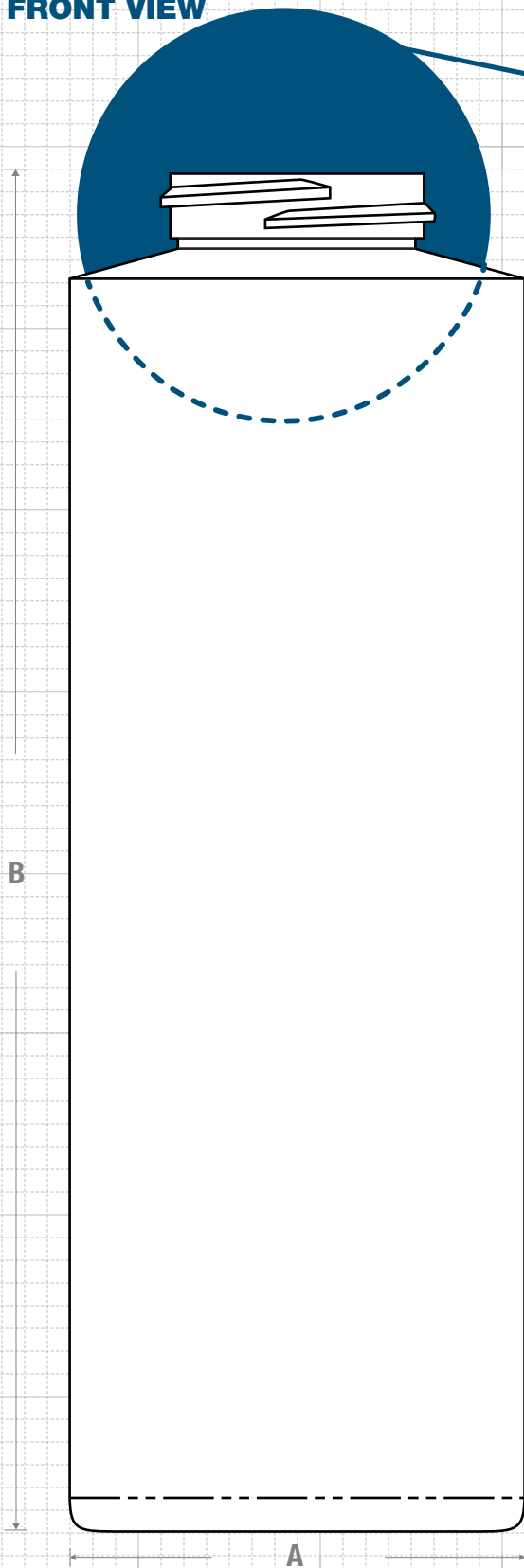

NECK & THREAD DETAIL

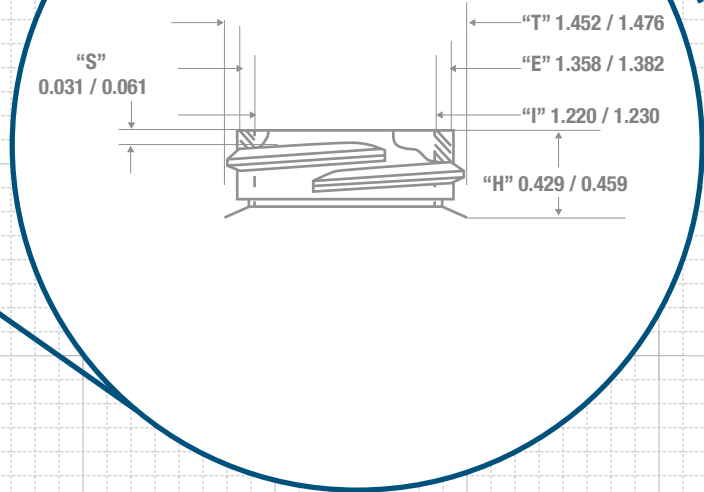

- HDPE
- LDPE
- PP
- OTHER

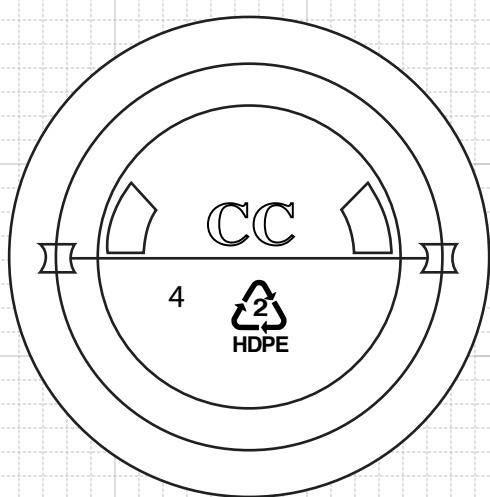

BOTTOM VIEW



CLASSIC CONTAINERS INC
 1700 S. Hellman Ave.
 Ontario, CA 91761
 Phone: 909-930-3610
 e-mail: info@classiccontainers.com
 www.classiccontainers.com

Drawing: 16 oz Cylinder Round 38/400	Gram Weight: 32 ± 2	Max Print Area (Height): 6.375"	Cases Per Pallet: 16
Stock Code: 001600010380000	Neck Finish: 38/400	Max Print Area (Width): 7.500"	Box Dimensions: 24 7/12 x 18 1/2 x 23
Manufacturing Process: Extrusion Blow Molding	Base Width (A): 2.500 ± 0.050	Case Pack: 231	Stock Material: HDPE
Overflow Capacity: 507 - 531 ml (17.2 - 18.0 oz)	Overall Height (B): 7.469 ± 0.050	Case Weight (lb): 19.2 ± 1	Rev #4 - 05/2016 Drawing not exactly to size.

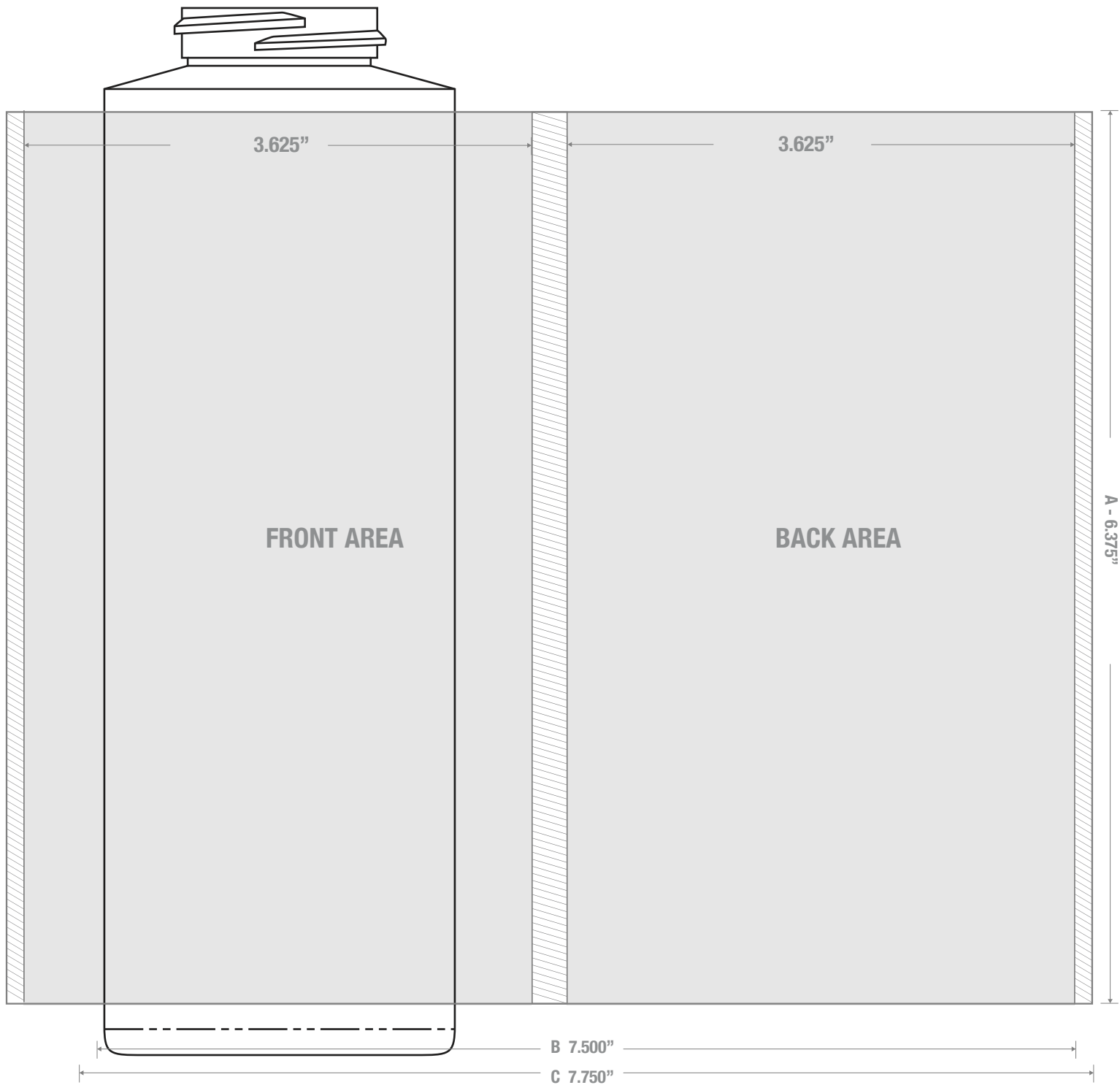

1700 S Hellman Ave, Ontario, California 91761
Phone: (909) 930-3610 | Fax: (909) 930-3640
e-mail: info@classiccontainers.com
www.classiccontainers.com

A - Total Height.
B - Max. Decorating Area.
C - Total bottle circumference.
▨ - Unprintable area.

WRAP LABELING SPECIFICATIONS: 16 oz CYLINDER ROUND 38/400

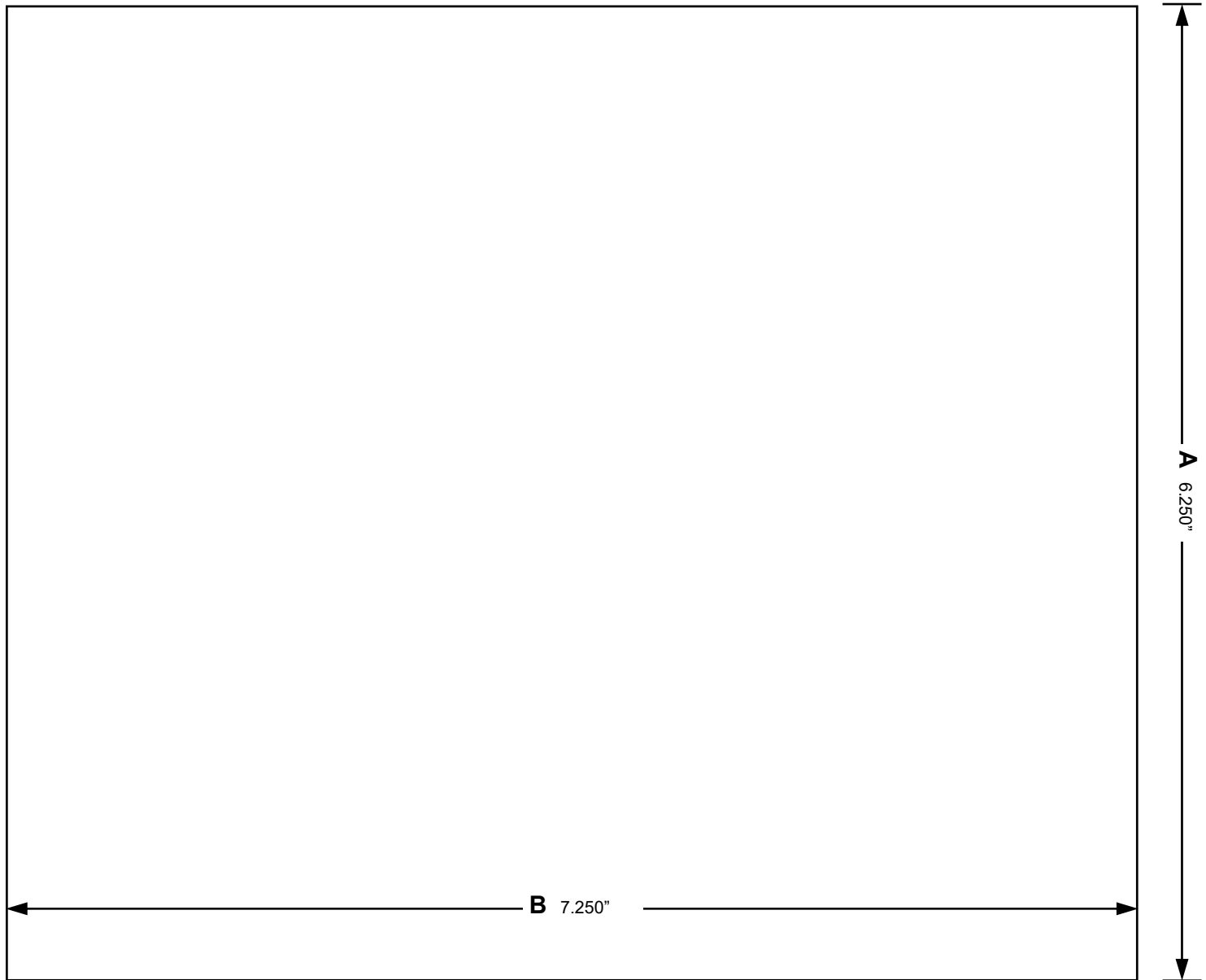

Maximum Label Area

A - Total Height. B - Total Width