

FRONT VIEW

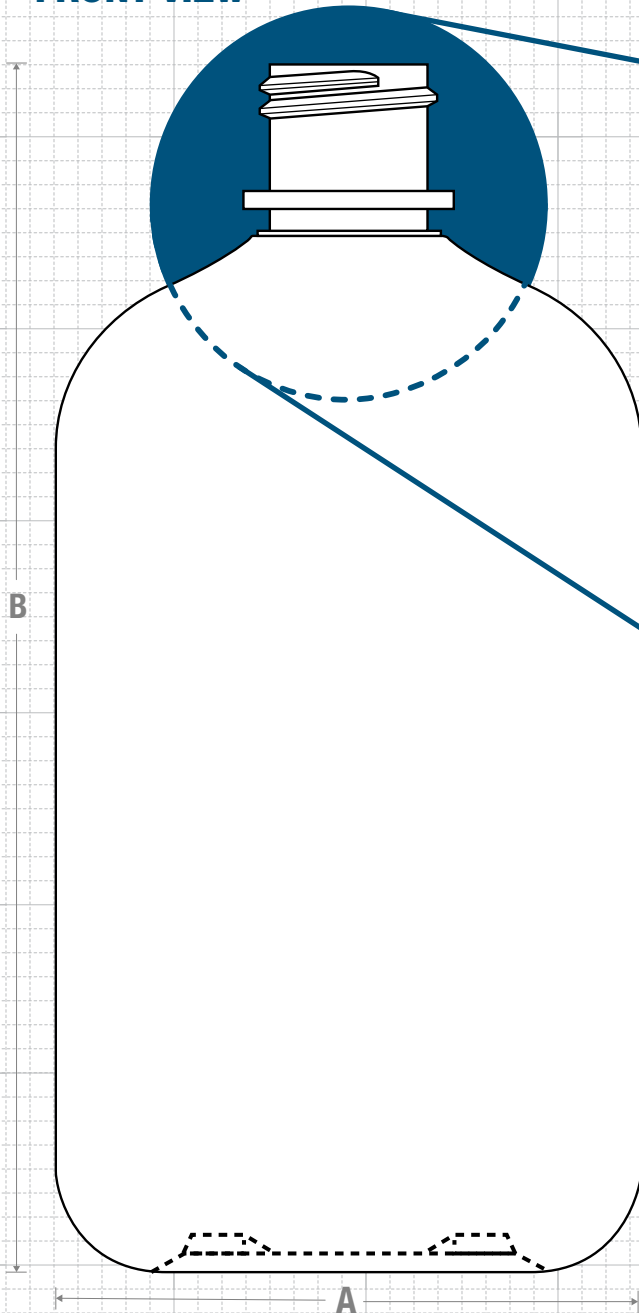

NECK & THREAD DETAIL

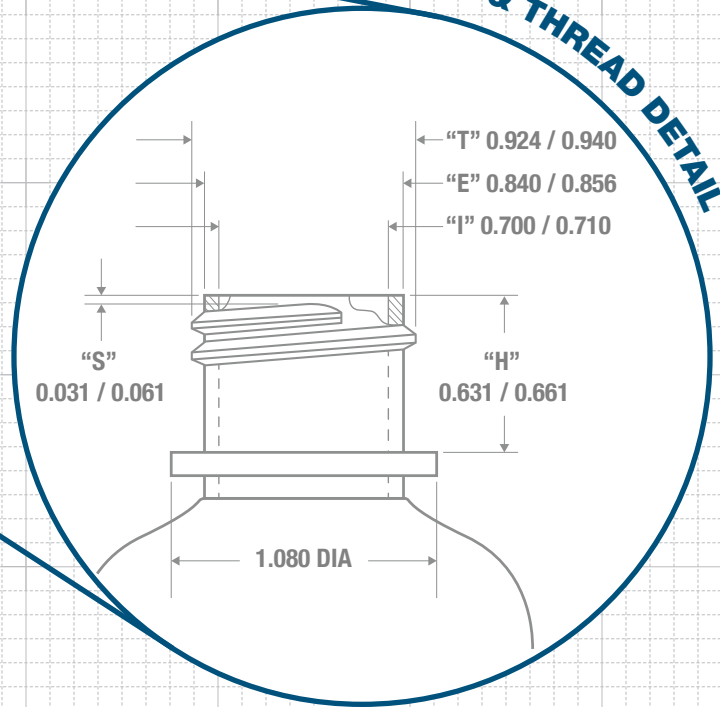

BOTTOM VIEW

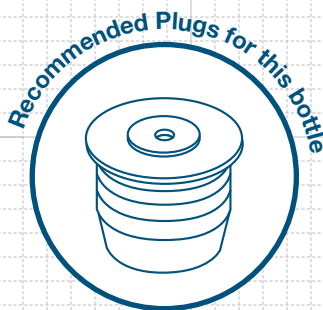
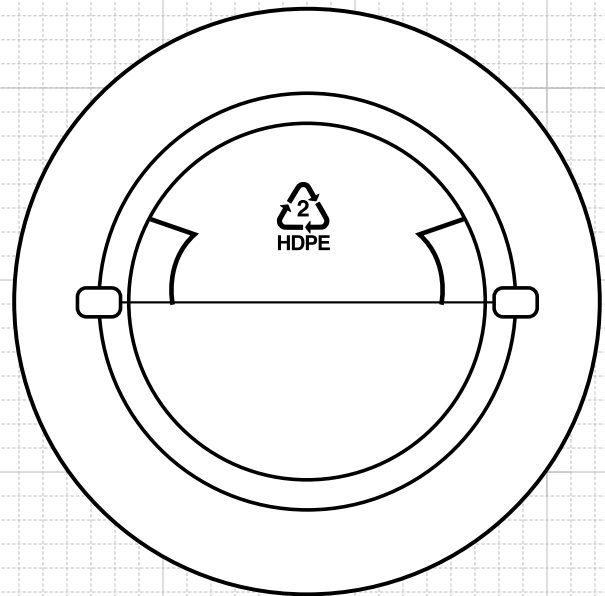

FRICTION FIT

Drawing: 16 oz Boston Round 24/410 with Ring	Gram Weight: 34 ± 2	Max Print Area (Height): 3.500"	Cases Per Pallet: 16
Stock Code: 0016000624R0000	Neck Finish: 24/410 W/R	Max Print Area (Width): 9.312"	Box Dimensions: 24 7/16 x 18 1/2 x 23
Manufacturing Process: Extrusion Blow Molding	Base Width (A): 3.050 ± 0.050	Case Pack: 198	Stock Material:
Overflow Capacity: 552 - 575 ml (18.7 - 19.5 oz)	Overall Height (B): 6.290 ± 0.050	Case Weight (lb): 17.7 ± 0.9	Rev #8 - 07/2016 Drawing not exactly to size.



CLASSIC CONTAINERS INC
 1700 S. Hellman Ave.
 Ontario, CA 91761
 Phone: 909-930-3610
 e-mail: info@classiccontainers.com
www.classiccontainers.com

PRINTING SPECIFICATIONS: 16 oz BOSTON ROUND

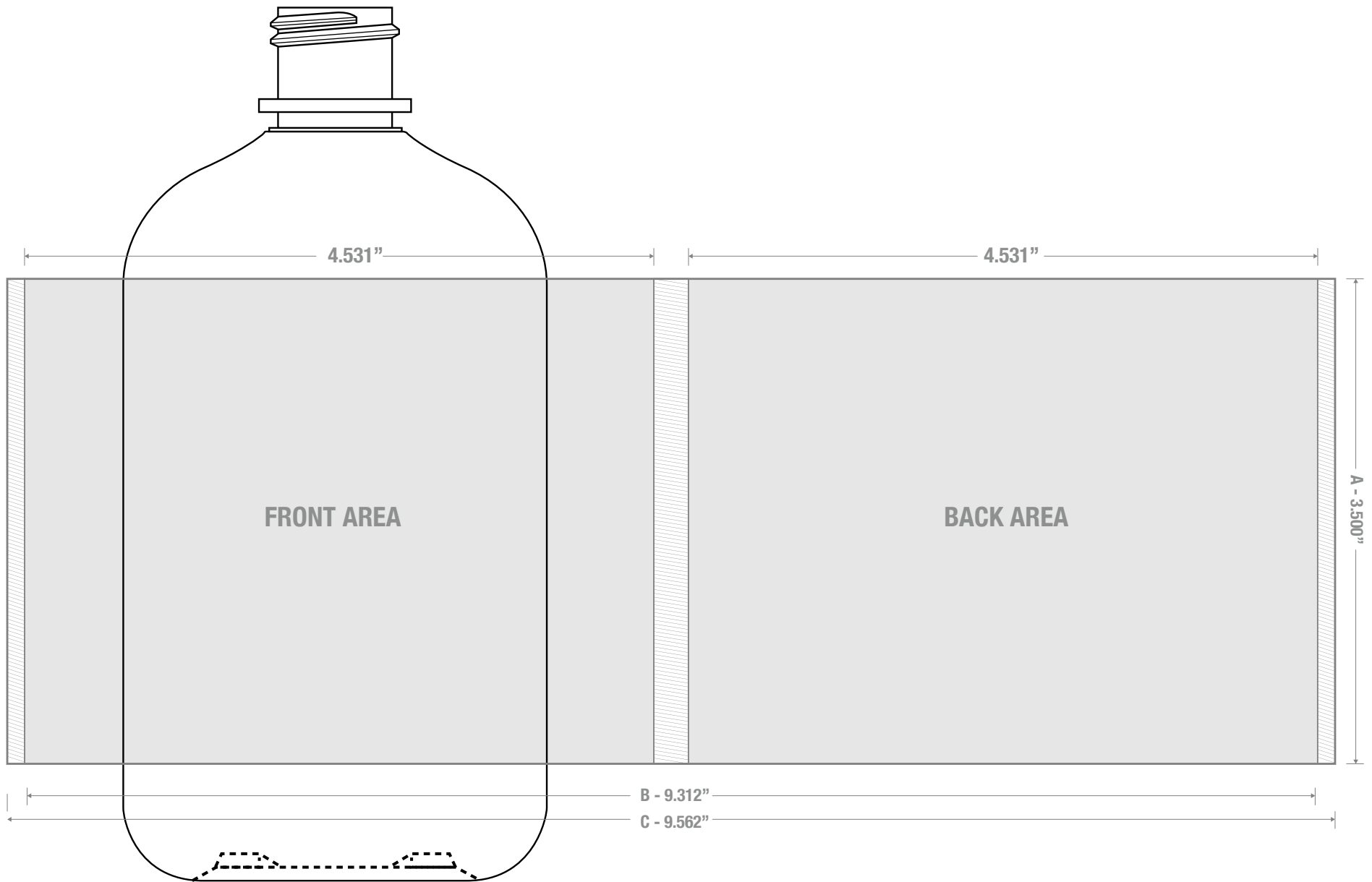

1700 S Hellman Ave, Ontario, California 91761
Phone: (909) 930-3610 | Fax: (909) 930-3640
e-mail: info@classiccontainers.com
www.classiccontainers.com

A - Total Height.
B - Max. Decorating Area.
C - Total bottle circumference.
▨ - Unprintable area.

LABELING SPECIFICATIONS: 16 oz BOSTON ROUND

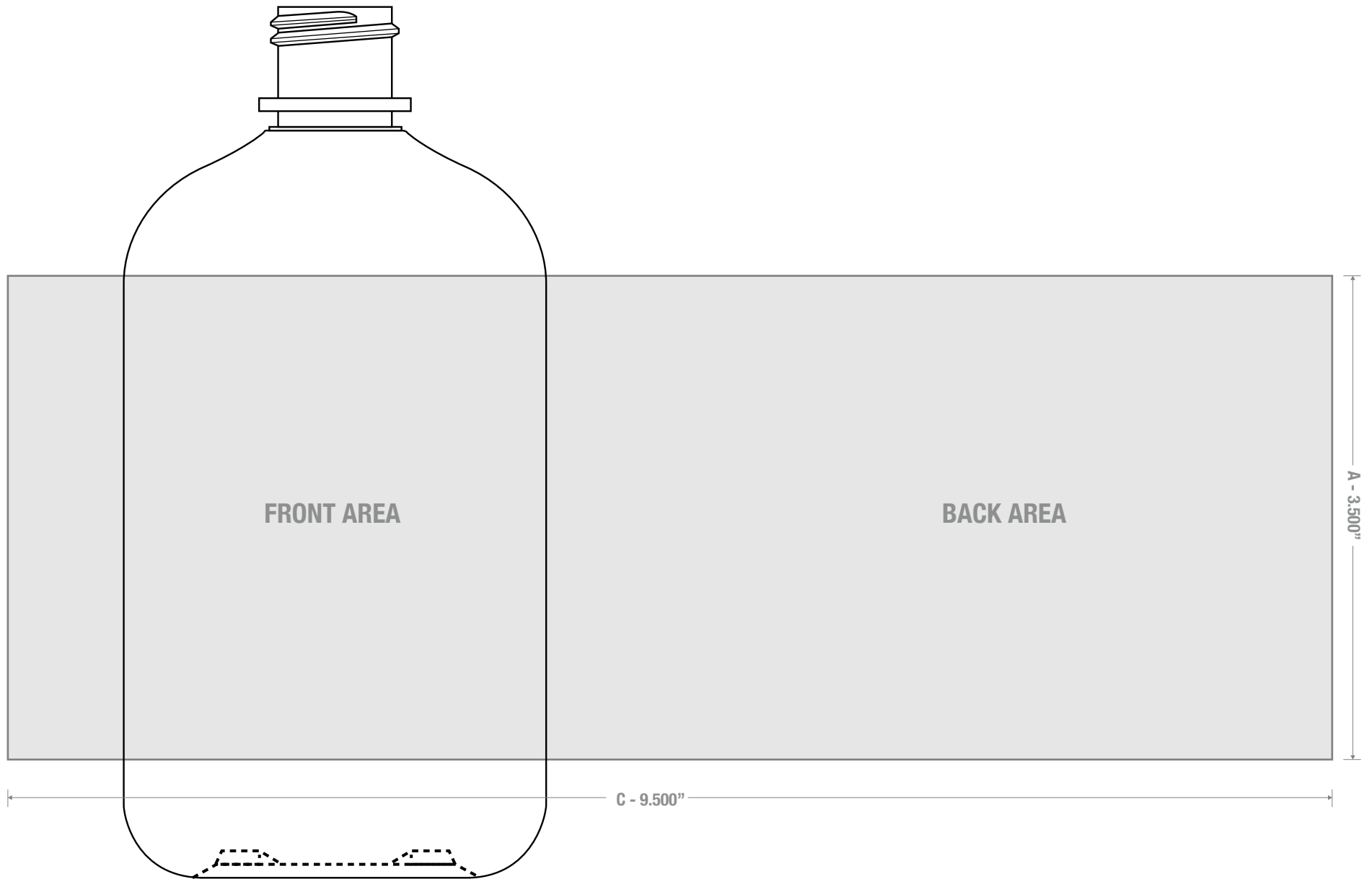

**LASSIC
CONTAINERS
Inc.**

1700 S Hellman Ave, Ontario, California 91761
Phone: (909) 930-3610 | Fax: (909) 930-3640
e-mail: info@classiccontainers.com
www.classiccontainers.com

A - Total Height.
B - Max. Decorating Area.