

**FRONT VIEW**

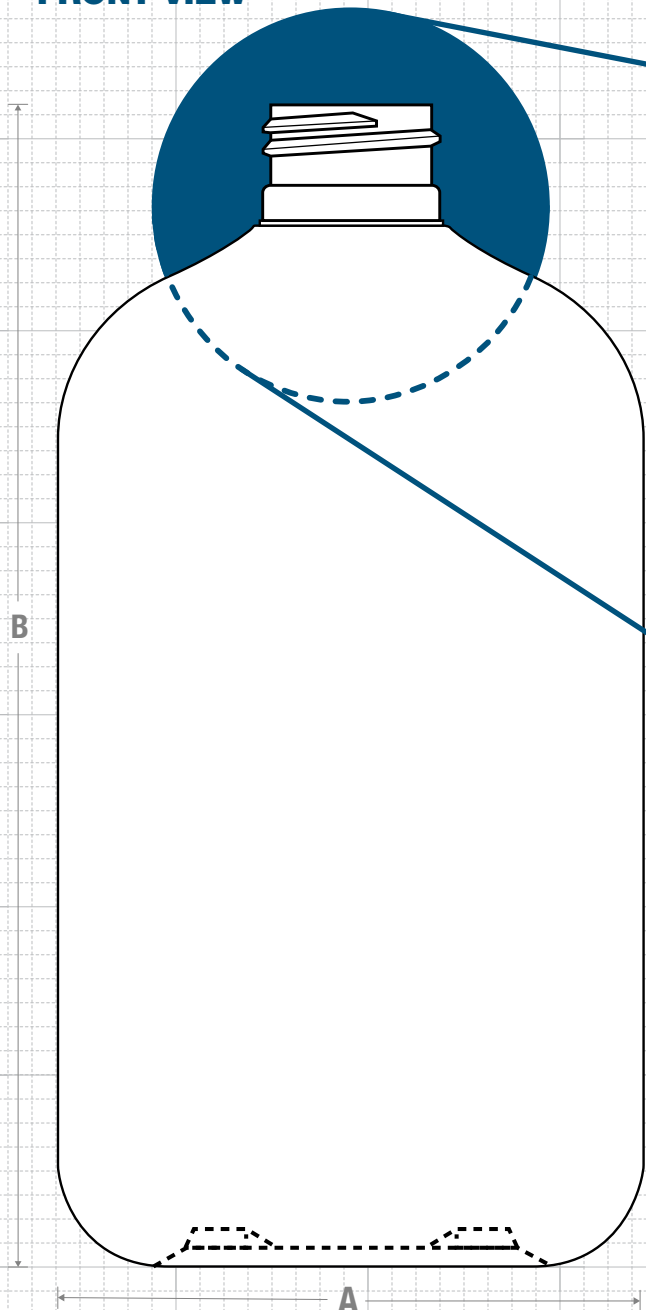

**NECK & THREAD DETAIL**

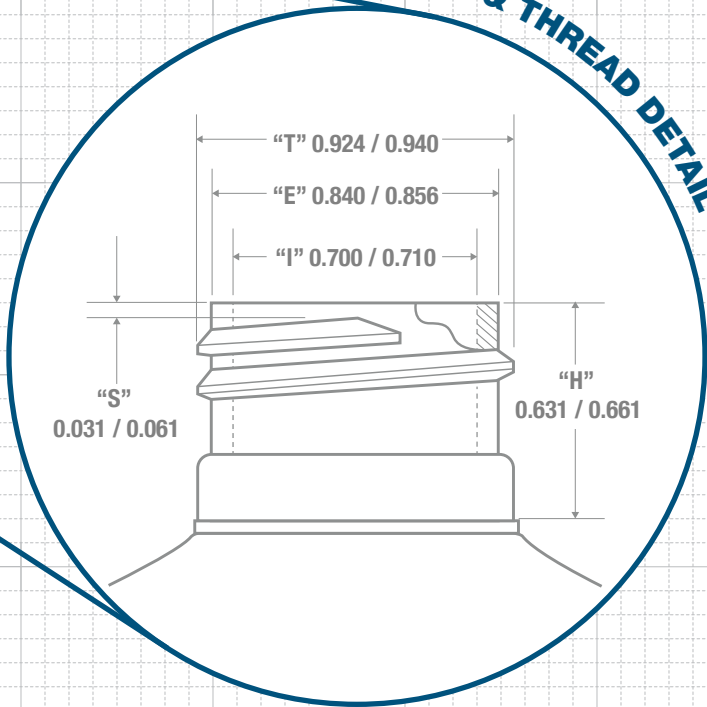

**BOTTOM VIEW**

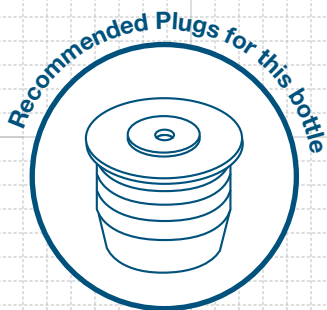
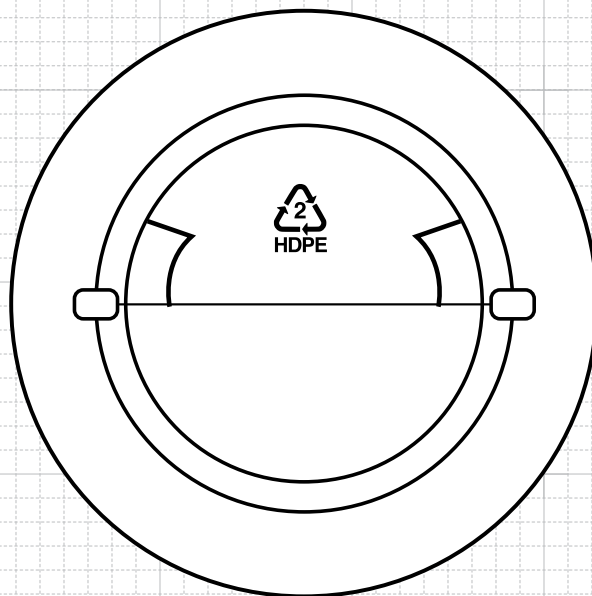

**FRICTION FIT**

Drawing: <b>16 oz Boston Round 24/410</b>	Gram Weight: <b>34 ± 2</b>	Max Print Area (Height): <b>3.500"</b>	Cases Per Pallet: <b>16</b>
Stock Code: <b>001600060240000</b>	Neck Finish: <b>24/410</b>	Max Print Area (Width): <b>9.312"</b>	Box Dimensions: <b>24 7/16 x 18 1/2 x 23</b>
Manufacturing Process: <b>Extrusion Blow Molding</b>	Base Width (A): <b>3.050 ± 0.050</b>	Case Pack: <b>198</b>	Stock Material:
Overflow Capacity: <b>552 - 575 ml (18.7 - 19.5 oz)</b>	Overall Height (B): <b>6.050 ± 0.050</b>	Case Weight (lb): <b>17.7 ± 0.9</b>	Rev #6 - 07/2016      Drawing not exactly to size.



**CLASSIC CONTAINERS INC**  
 1700 S. Hellman Ave.  
 Ontario, CA 91761  
 Phone: 909-930-3610  
 e-mail: info@classiccontainers.com  
 www.classiccontainers.com

# PRINTING SPECIFICATIONS: 16 oz BOSTON ROUND

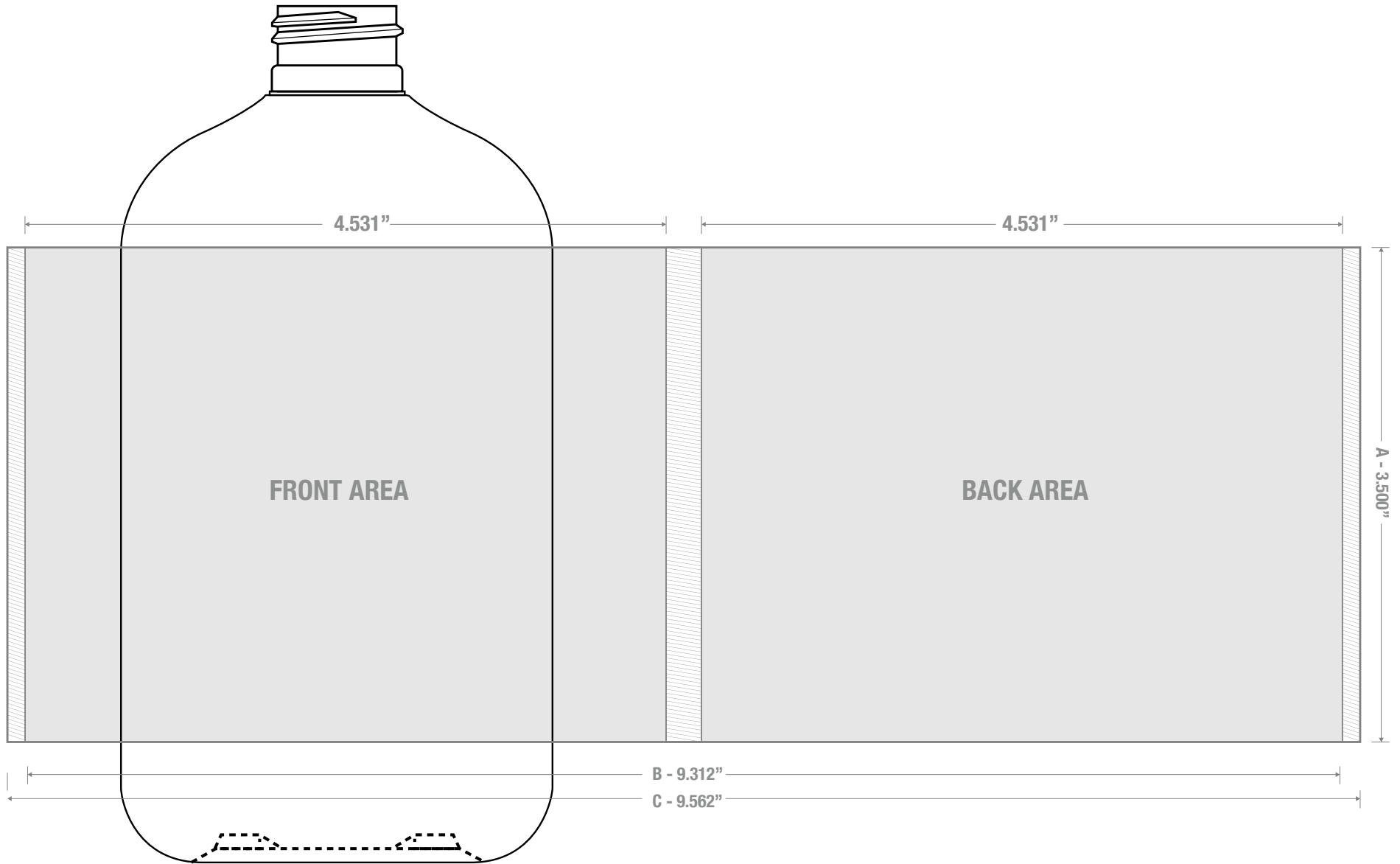

1700 S Hellman Ave, Ontario, California 91761  
Phone: (909) 930-3610 | Fax: (909) 930-3640  
e-mail: [info@classiccontainers.com](mailto:info@classiccontainers.com)  
[www.classiccontainers.com](http://www.classiccontainers.com)

A - Total Height.  
B - Max. Decorating Area.  
C - Total bottle circumference.  
▨ - Unprintable area.

# LABELING SPECIFICATIONS: 16 oz BOSTON ROUND

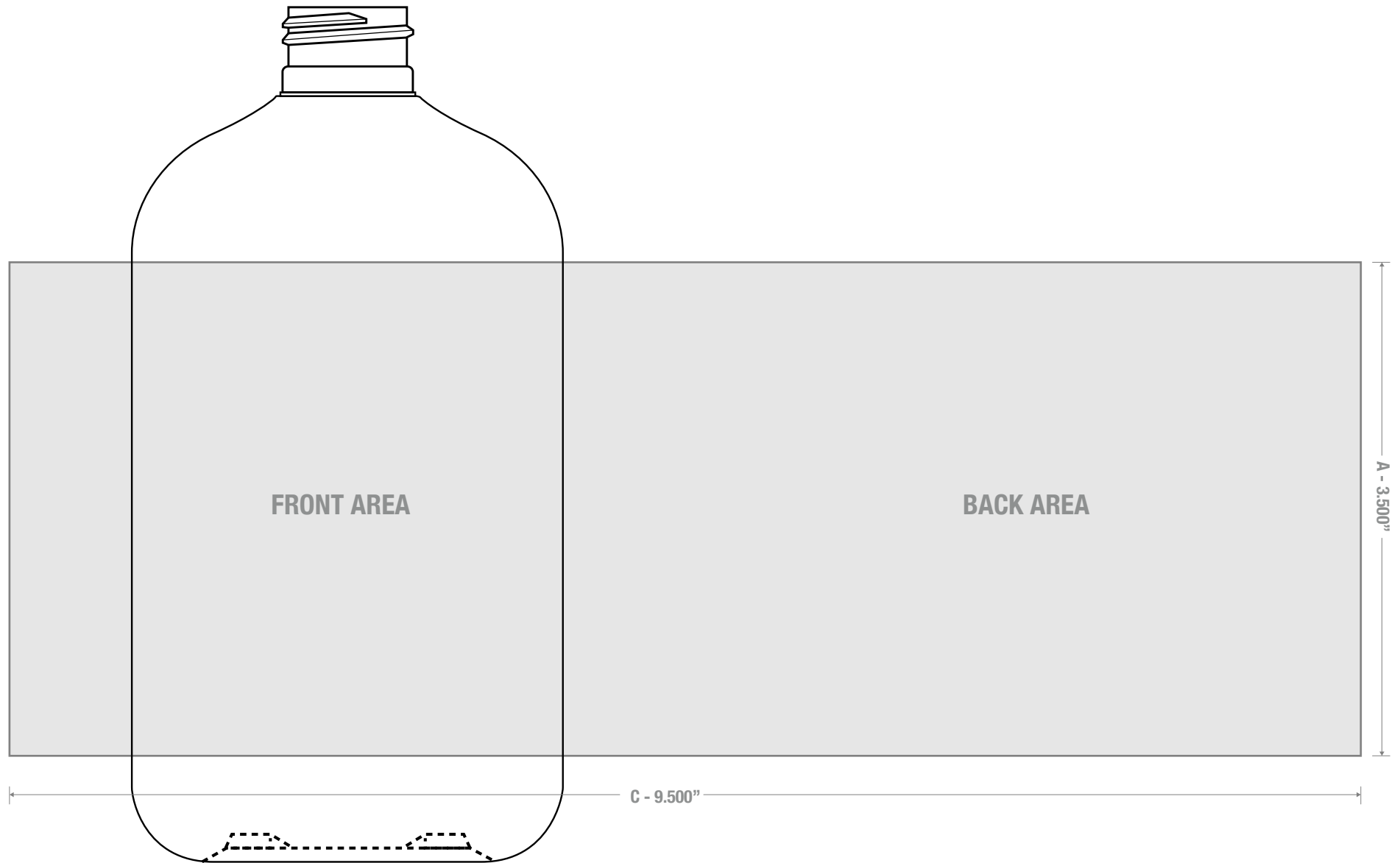

1700 S Hellman Ave, Ontario, California 91761  
Phone: (909) 930-3610 | Fax: (909) 930-3640  
e-mail: [info@classiccontainers.com](mailto:info@classiccontainers.com)  
[www.classiccontainers.com](http://www.classiccontainers.com)

A - Total Height.  
B - Max. Decorating Area.