



Drawing:
150 ml Boston Round 24/415

Stock Code:
015000060251700

Manufacturing Process:
Stretch Blow Molding

Overflow Capacity:
156 - 168 ml (5.3 - 5.7 oz)

Gram Weight:
15 ± 1

Neck Finish:
24/415

Base Width (A):
2.040 ± 0.050

Overall Height (B):
4.140 ± 0.050

Max Print Area (Height):
2.240"

Max Print Area (Width):
5.809"

Case Pack: 336

Case Weight (lb): 13.3 ± 0.7

Cases Per Pallet: 25

Box Dimensions:
23 5/8 x 15 9/16 x 17

Stock Material:



CLASSIC CONTAINERS INC
1700 S. Hellman Ave.
Ontario, CA 91761
Phone: 909-930-3610
e-mail: info@classiccontainers.com
www.classiccontainers.com



FRONT VIEW

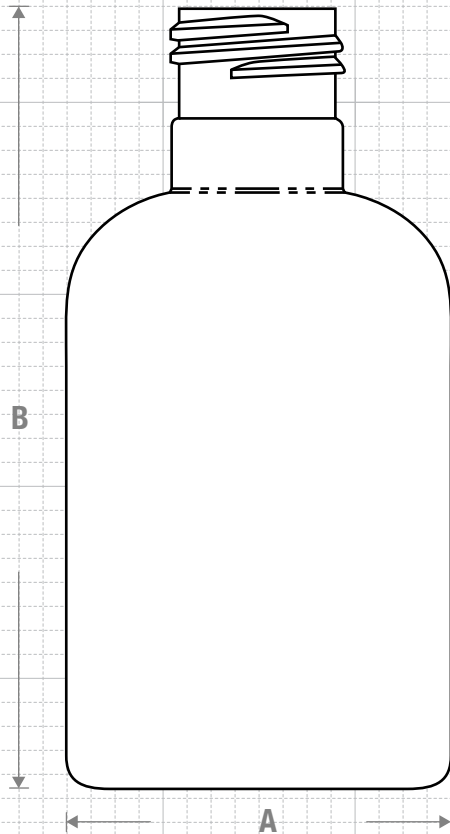

NECK & THREAD DETAIL

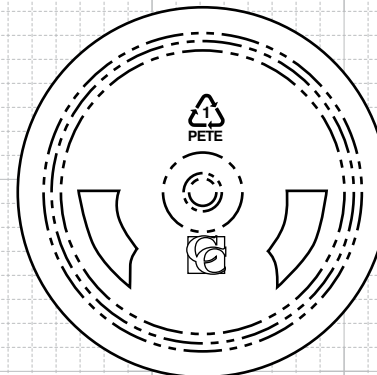
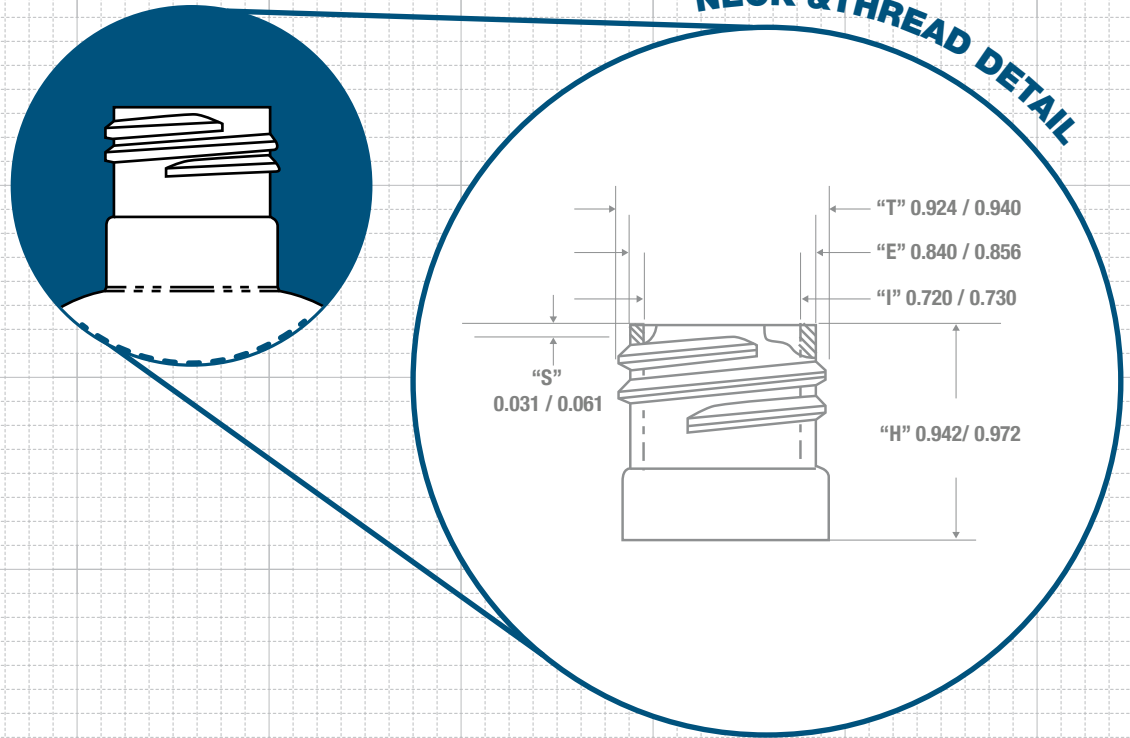

BOTTOM VIEW

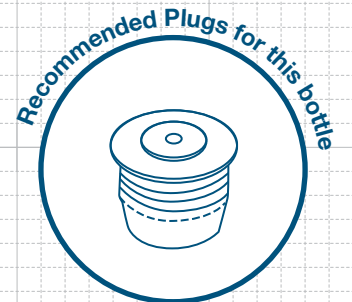

FRICION FIT

PRINTING SPECIFICATIONS: 150 ml BOSTON ROUND 24/415

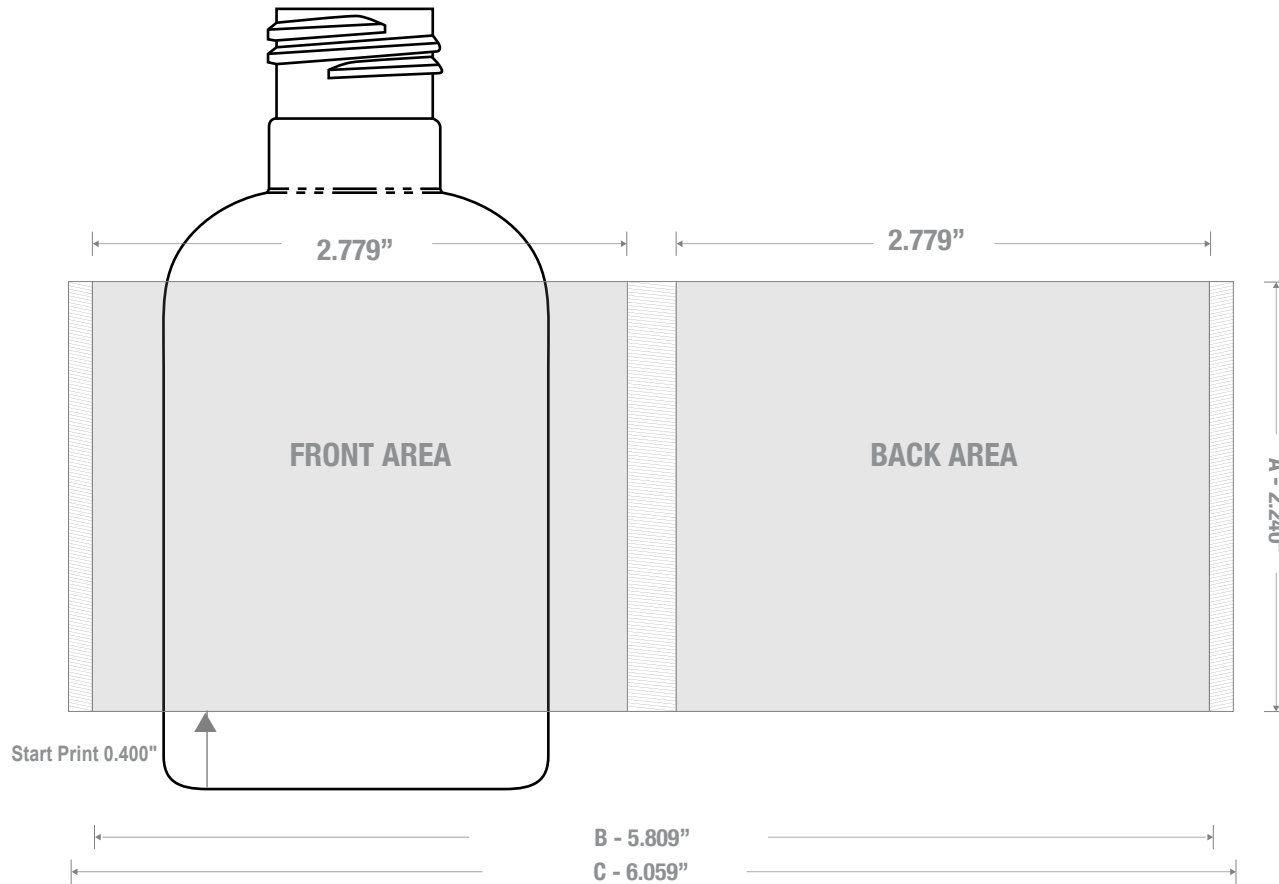

1700 S Hellman Ave, Ontario, California 91761
 Phone: (909) 930-3610 | Fax: (909) 930-3640
 e-mail: info@classiccontainers.com
www.classiccontainers.com

A - Total Height.
B - Max. Decorating Area.
C - Total bottle circumference.
 - Unprintable area.

LABELING SPECIFICATIONS: 150 ml BOSTON ROUND 24/415



1700 S Hellman Ave, Ontario, California 91761
Phone: (909) 930-3610 | Fax: (909) 930-3640
e-mail: info@classiccontainers.com
www.classiccontainers.com

A - Total Height.
B - Max. Decorating Area.