

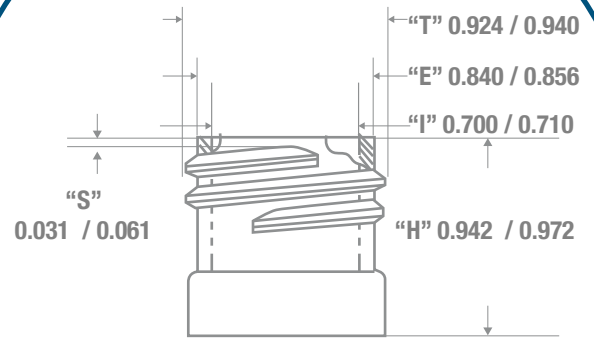

NECK & THREAD DETAIL

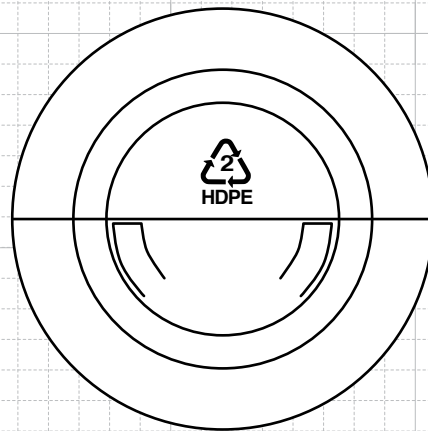

FRONT VIEW

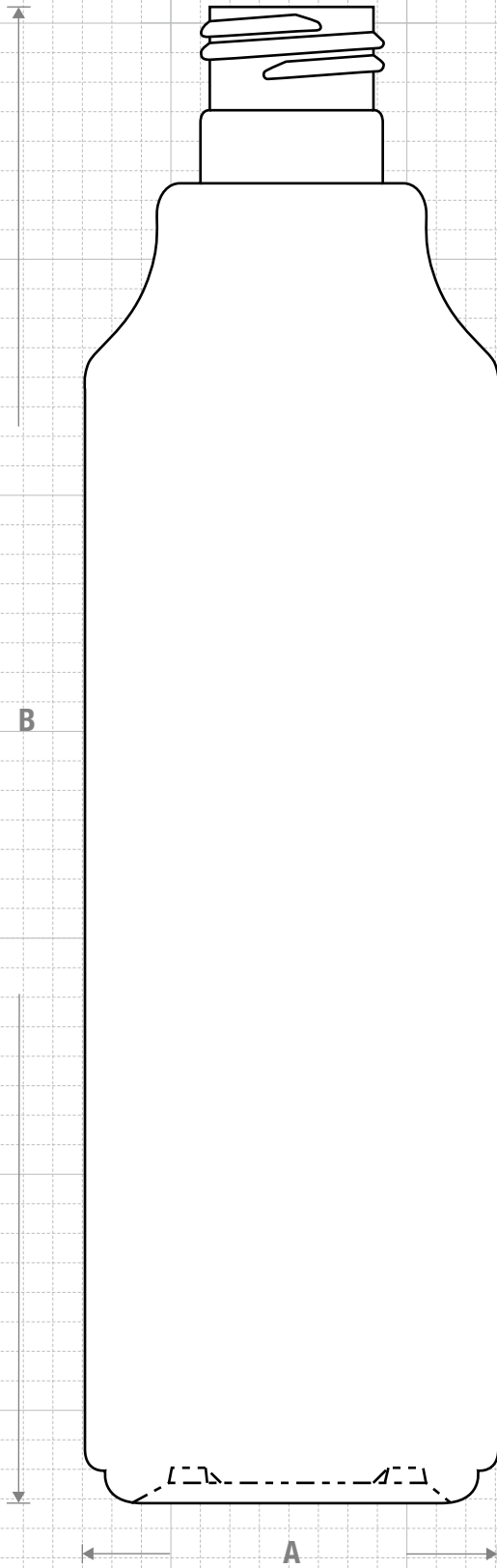

BOTTOM VIEW

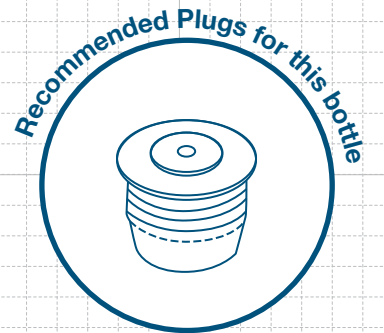

FRICTION FIT



CLASSIC CONTAINERS INC
 1700 S. Hellman Ave.
 Ontario, CA 91761
 Phone: 909-930-3610
 e-mail: info@classiccontainers.com
 www.classiccontainers.com

Drawing:
12 oz Queen Round 24/415

Gram Weight:
28 ± 2

Max Print Area (Height):
5.500"

Cases Per Pallet: **16**

Stock Code:
001201260250000

Neck Finish:
24/415

Max Print Area (Width):
6.687"

Box Dimensions:
24 7/16 x 18 1/2 x 23

Manufacturing Process:
Extrusion Blow Molding

Base Width (A):
2.200± 0.050

Case Pack: **288**

Stock Material:



Overflow Capacity:
375- 392 ml (12.7 - 13.3 oz)

Overall Height (B):
8.104 ± 0.050

Case Weight (lb): **20.7 ± 1.3**

Rev #3 06/2016

Drawing not exactly to size.

