

**FRONT VIEW**

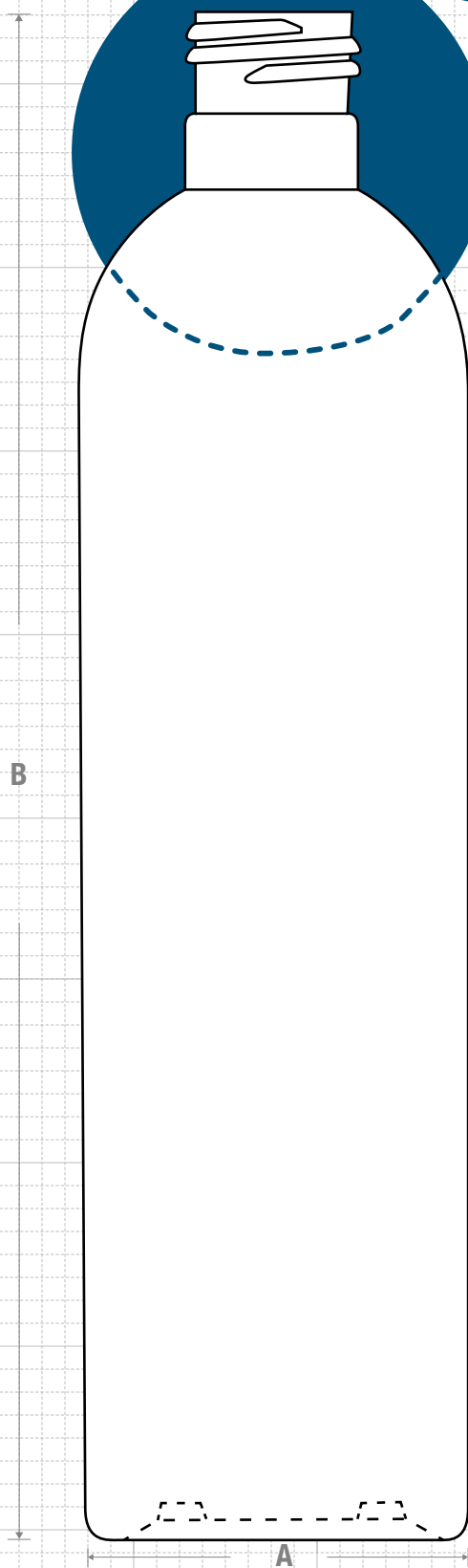

**NECK & THREAD DETAIL**

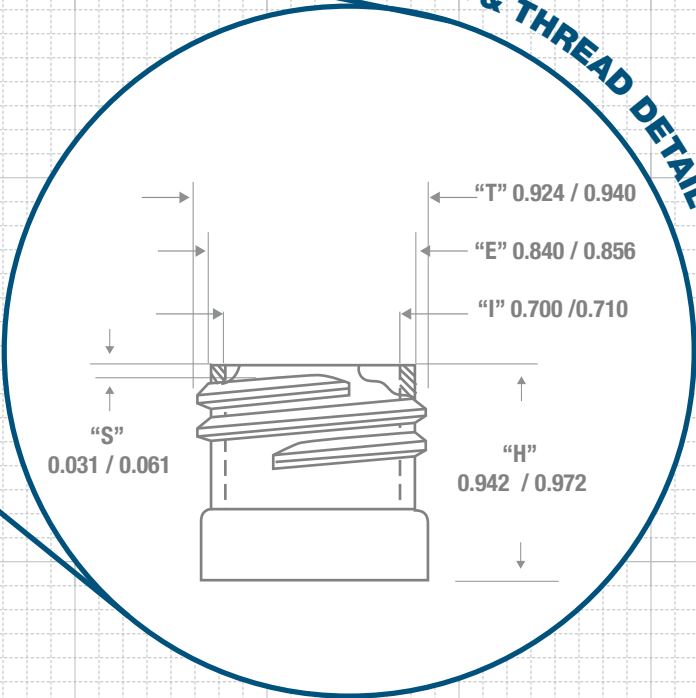

- HDPE
- LDPE
- PP
- OTHER

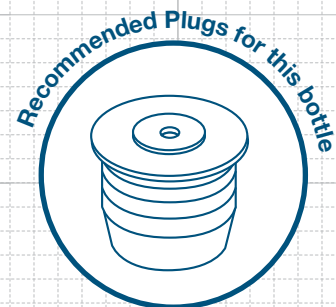

**FRICITION FIT**

**BOTTOM VIEW**

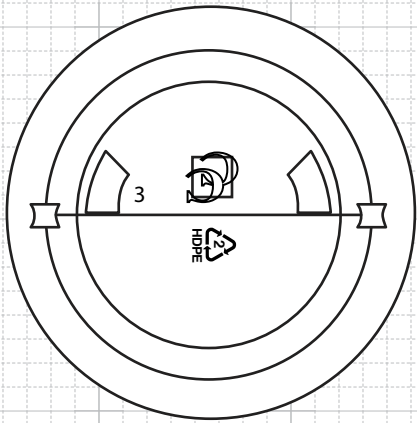

**CLASSIC CONTAINERS INC**  
 1700 S. Hellman Ave.  
 Ontario, CA 91761  
 Phone: 909-930-3610  
 e-mail: info@classiccontainers.com  
 www.classiccontainers.com

Drawing: <b>12 oz Imperial Round 24/415</b>	Gram Weight: <b>28 ± 2 grs</b>	Max Print Area (Height): <b>5.750"</b>	Cases Per Pallet: <b>16</b>
Stock Code: <b>001200050250000</b>	Neck Finish: <b>24/415</b>	Max Print Area (Width): <b>6.500"</b>	Box Dimensions: <b>24 7/16 x 18 1/2 x 23</b>
Manufacturing Process: <b>Extrusion Blow Molding</b>	Base Width (A): <b>2.146 ± 0.05</b>	Case Pack: <b>276</b>	Stock Material:  HDPE
Overflow Capacity: <b>384- 401 ml (13.0- 13.6 oz)</b>	Overall Height (B): <b>8.308 ± 0.060</b>	Case Weight (lb): <b>20.0 ± 1.2</b>	Rev #2 -06/2016      Drawing not exactly to size.

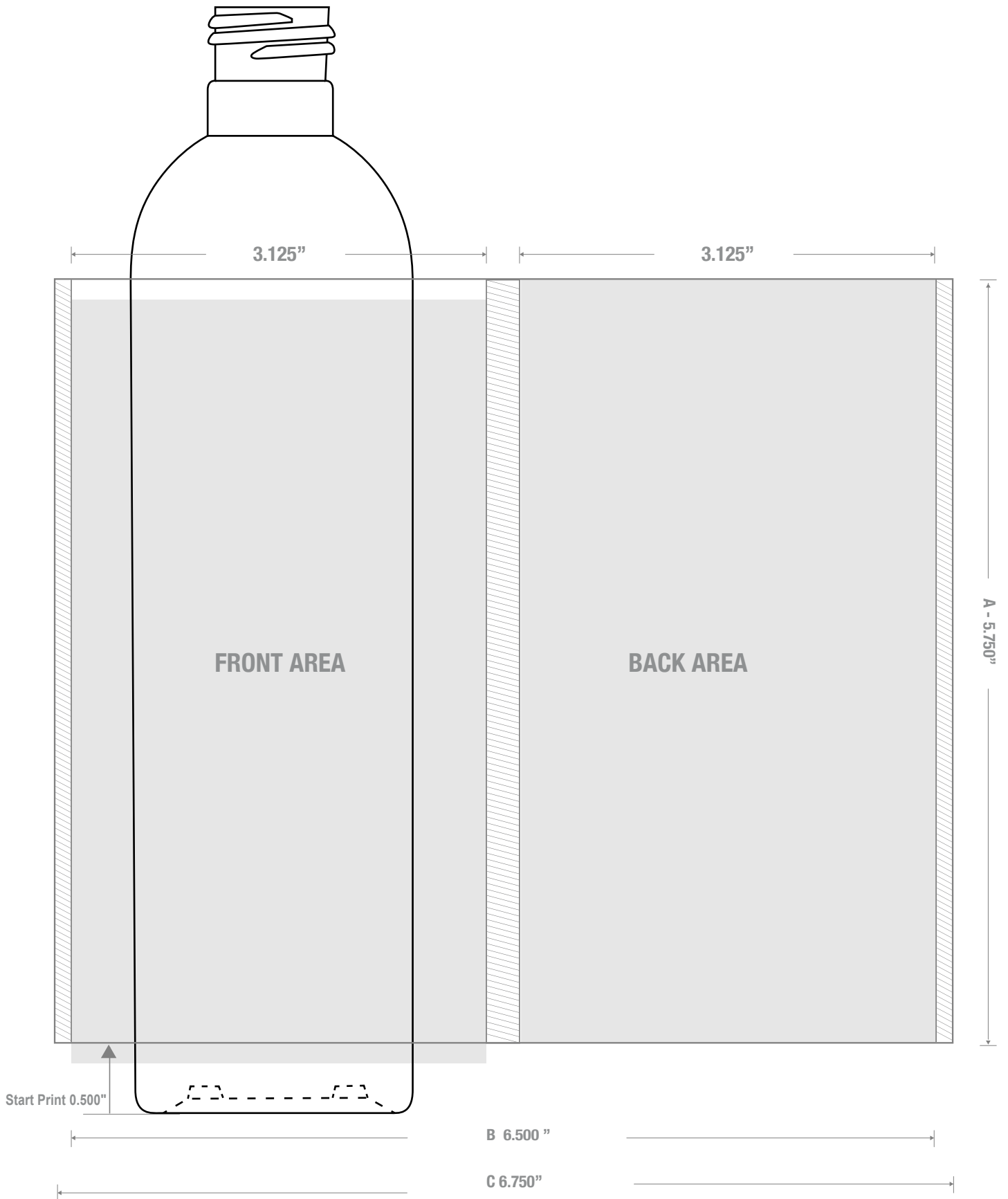

1700 S Hellman Ave, Ontario, California 91761  
Phone: (909) 930-3610 | Fax: (909) 930-3640  
e-mail: [info@classiccontainers.com](mailto:info@classiccontainers.com)  
[www.classiccontainers.com](http://www.classiccontainers.com)

**A - Total Height.**  
**B - Max. Decorating Area.**  
**C - Total bottle circumference.**  
☐ Unprintable area

Labeling Area



1700 S Hellman Ave, Ontario, California 91761  
Phone: (909) 930-3610 | Fax: (909) 930-3640  
e-mail: [info@classiccontainers.com](mailto:info@classiccontainers.com)  
[www.classiccontainers.com](http://www.classiccontainers.com)

A - Total Height.  
B - Max. Decorating Area.