

FRONT VIEW

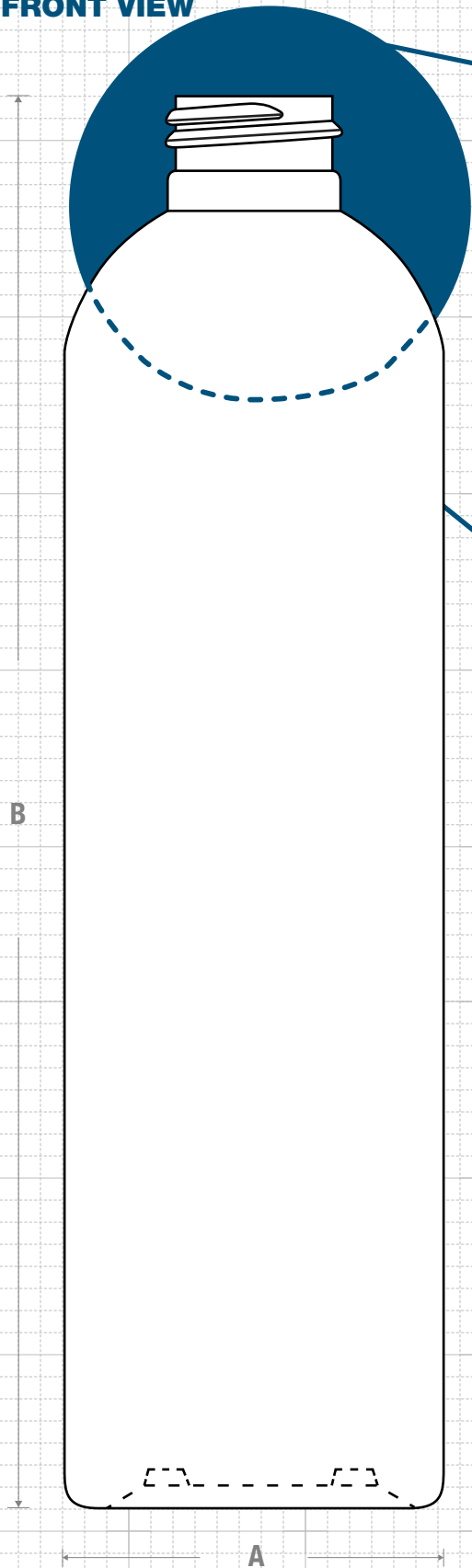

NECK & THREAD DETAIL

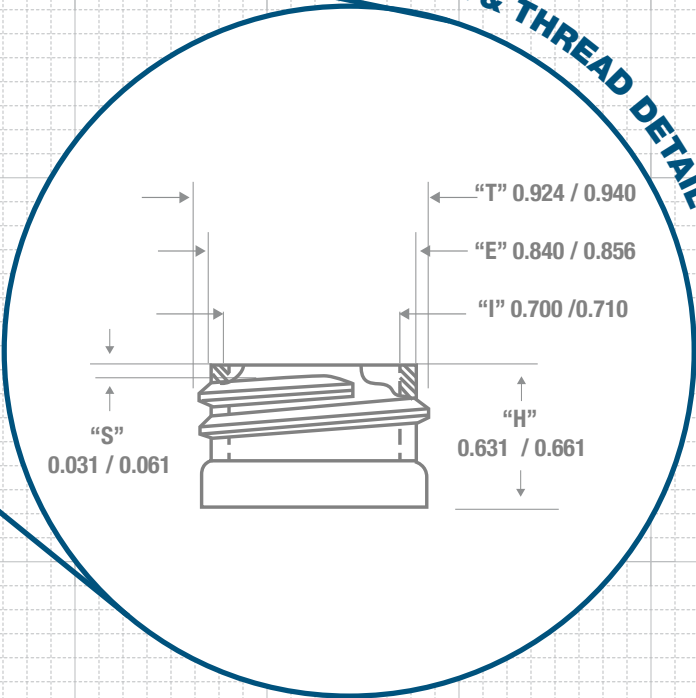

- HDPE
- LDPE
- PP
- OTHER

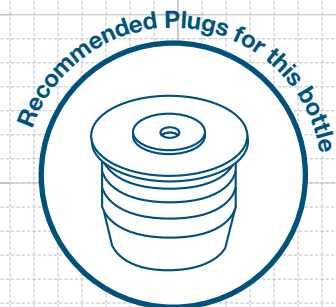

BOTTOM VIEW

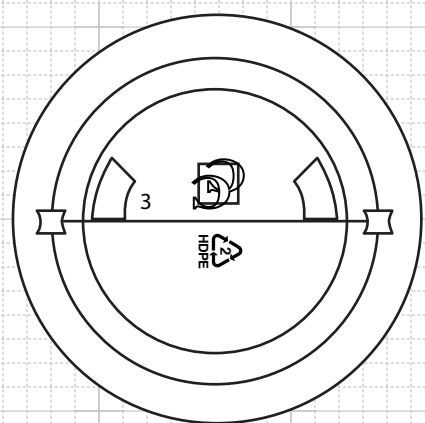

FRICITION FIT



CLASSIC CONTAINERS INC
 1700 S. Hellman Ave.
 Ontario, CA 91761
 Phone: 909-930-3610
 e-mail: info@classiccontainers.com
 www.classiccontainers.com

Drawing: 12 oz Imperial Round 24/410	Gram Weight: 28 ± 2 grs	Max Print Area (Height): 5.750"	Cases Per Pallet: 16
Stock Code: 001200050240000	Neck Finish: 24/410	Max Print Area (Width): 6.500"	Box Dimensions: 24 7/16 x 18 1/2 x 23
Manufacturing Process: Extrusion Blow Molding	Base Width (A): 2.146 ± 0.05	Case Pack: 276	Stock Material: HDPE
Overflow Capacity: 381- 398 ml (12.9 - 13.5 oz)	Overall Height (B): 7.997 ± 0.060	Case Weight (lb): 20.0 ± 1.2	Rev #2 -6/2016 Drawing not exactly to size.

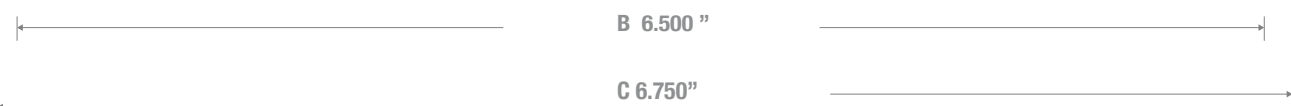
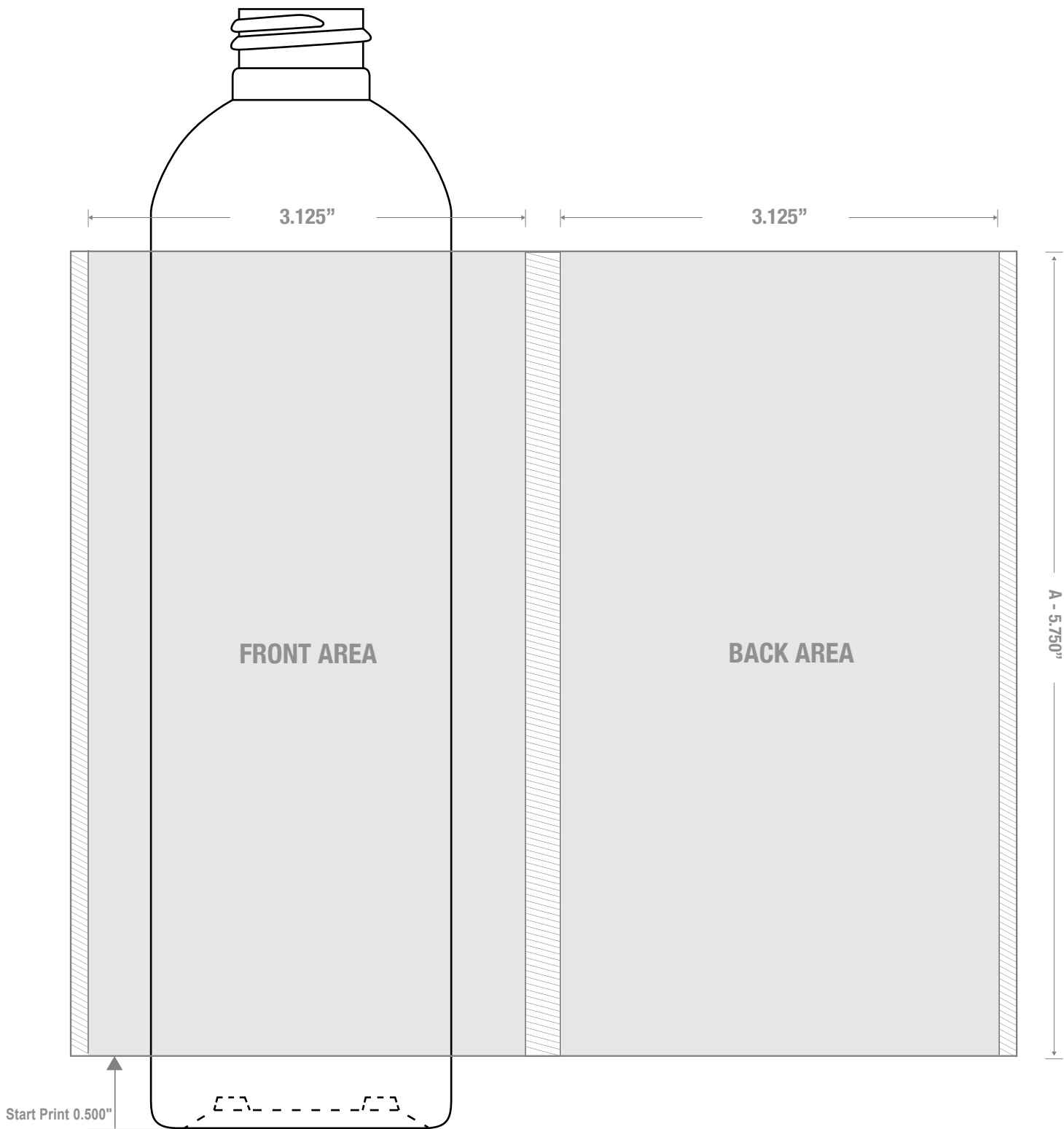

1700 S Hellman Ave, Ontario, California 91761
 Phone: (909) 930-3610 | Fax: (909) 930-3640
 e-mail: info@classiccontainers.com
www.classiccontainers.com

A - Total Height.
B - Max. Decorating Area.
C - Total bottle circumference.
 **Unprintable area**

Labeling Area

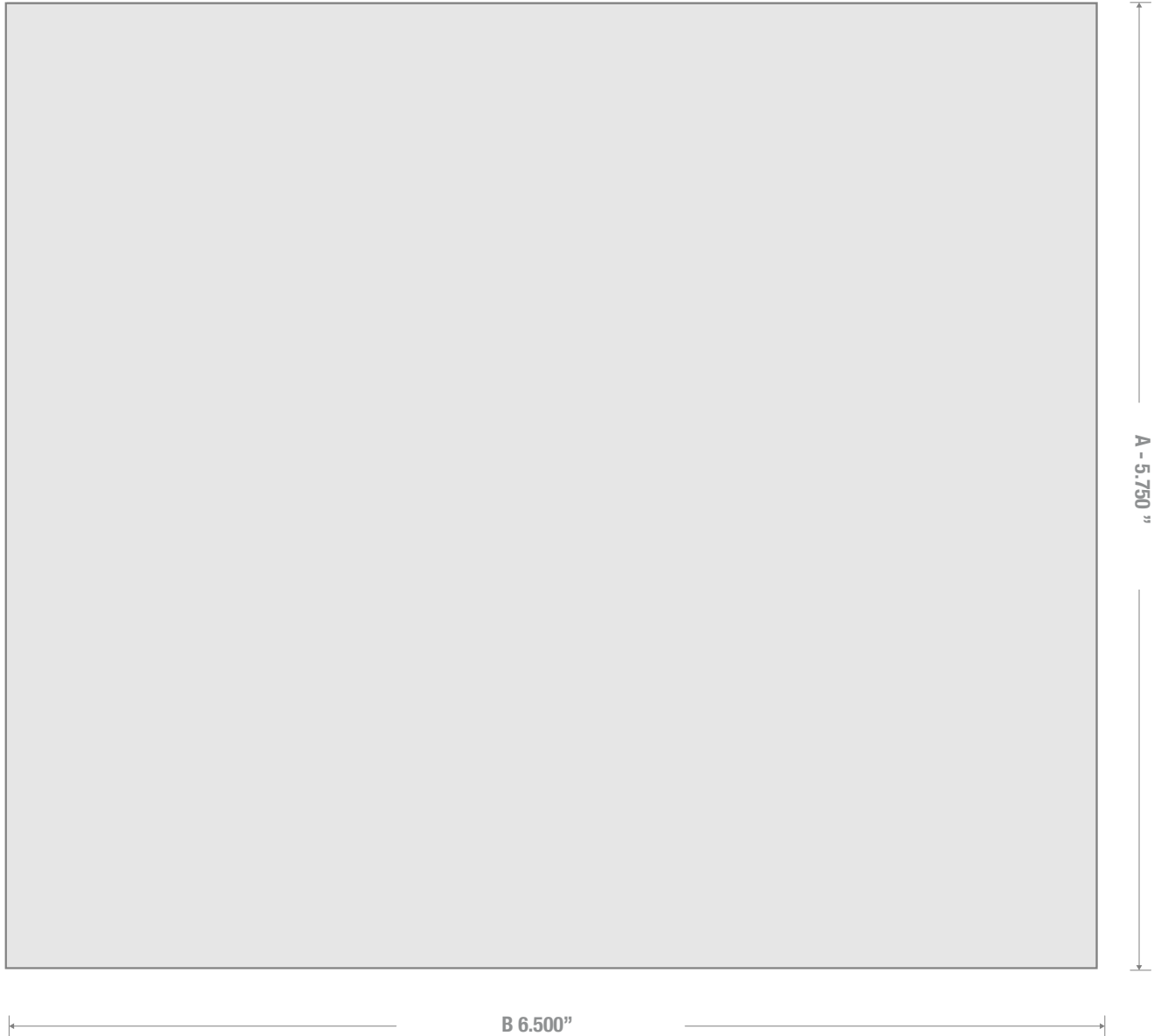

1700 S Hellman Ave, Ontario, California 91761
Phone: (909) 930-3610 | Fax: (909) 930-3640
e-mail: info@classiccontainers.com
www.classiccontainers.com

A - Total Height.
B - Max. Decorating Area.