

FRONT VIEW

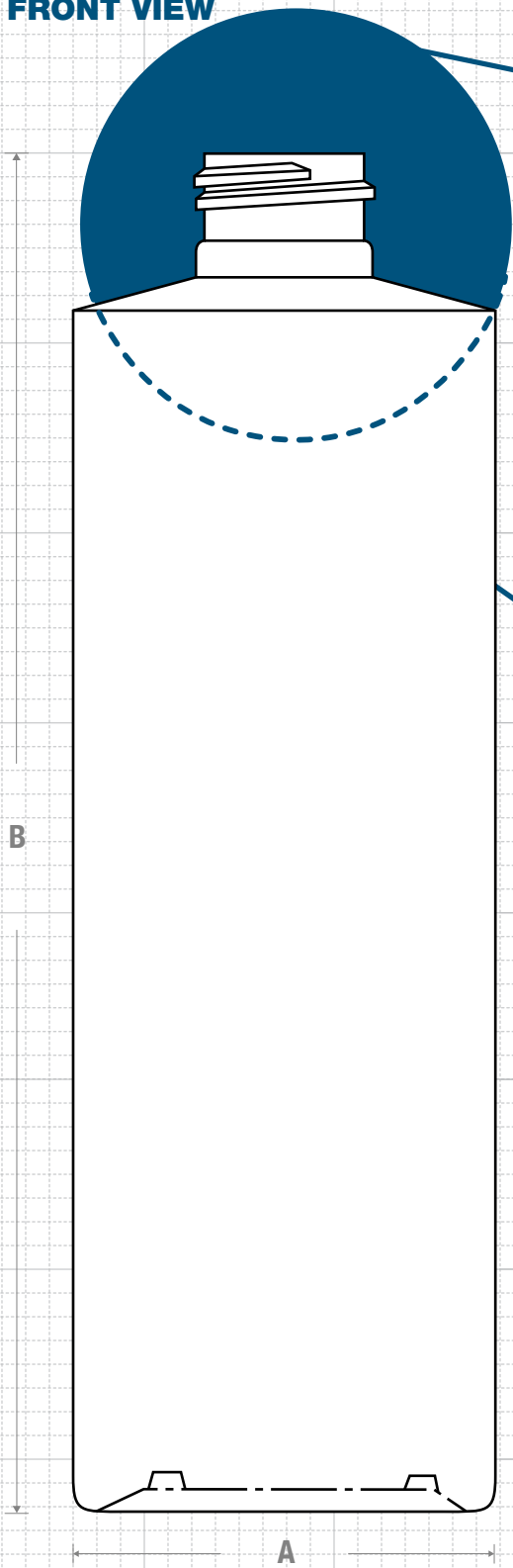

NECK & THREAD DETAIL

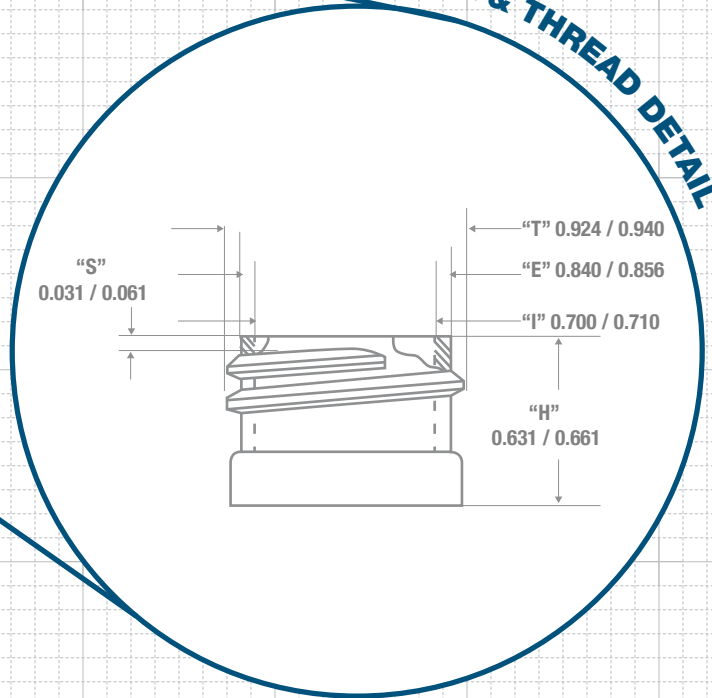

- HDPE
- LDPE
- PP
- OTHER

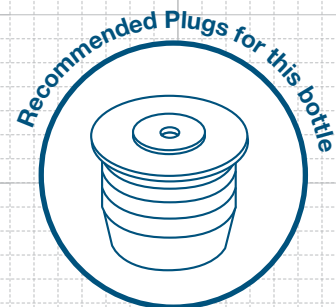

FRICTION FIT

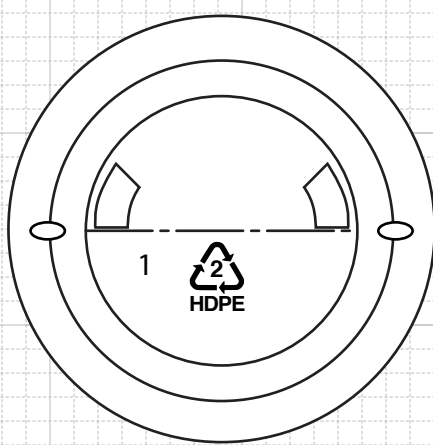

BOTTOM VIEW



CLASSIC CONTAINERS INC
 1700 S. Hellman Ave.
 Ontario, CA 91761
 Phone: 909-930-3610
 e-mail: info@classiccontainers.com
 www.classiccontainers.com

Drawing: 12 oz Cylinder Round 24/410	Gram Weight: 28 ± 2	Max Print Area (Height): 5.875"	Cases Per Pallet: 16
Stock Code: 001200010240000	Neck Finish: 24/410	Max Print Area (Width): 6.750"	Box Dimensions: 24 7/12 x 18 1/2 x 23
Manufacturing Process: Extrusion Blow Molding	Base Width (A): 2.225 ± 0.050	Case Pack: 288	Stock Material: HDPE
Overflow Capacity: 372 - 389 ml (12.6 - 13.2 oz)	Overall Height (B): 7.150 ± 0.050	Case Weight (lb): 20.7 ± 1.3	Rev #6 - 11/2016 Drawing not exactly to size.



1700 S Hellman Ave, Ontario, California 91761
Phone: (909) 930-3610 | Fax: (909) 930-3640
e-mail: info@classiccontainers.com
www.classiccontainers.com

A - Total Height.
B - Max. Decorating Area.
C - Total bottle circumference.
▨ - Unprintable area.

LABELING SPECIFICATIONS: 12 oz CYLINDER ROUND 24/410



1700 S Hellman Ave, Ontario, California 91761
Phone: (909) 930-3610 | Fax: (909) 930-3640
e-mail: info@classiccontainers.com
www.classiccontainers.com

A - Total Height.
B - Max. Decorating Area.