

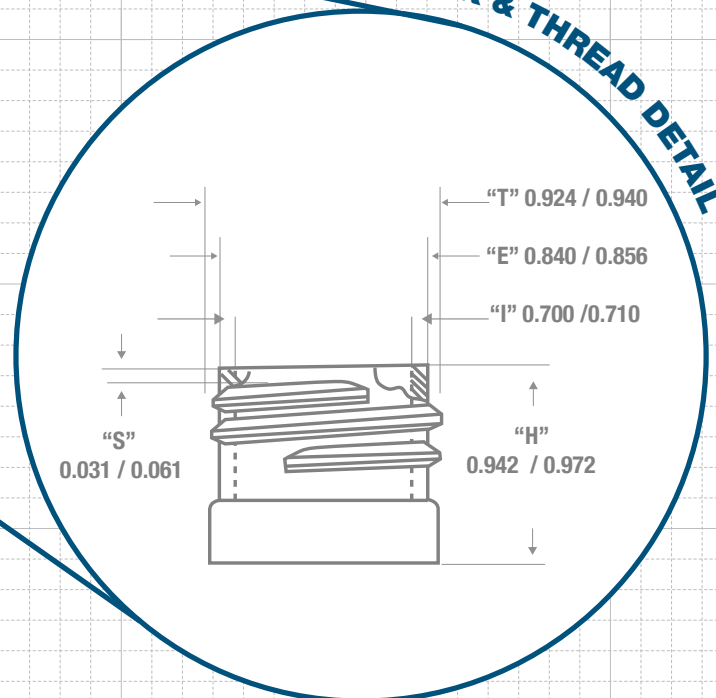

NECK & THREAD DETAIL

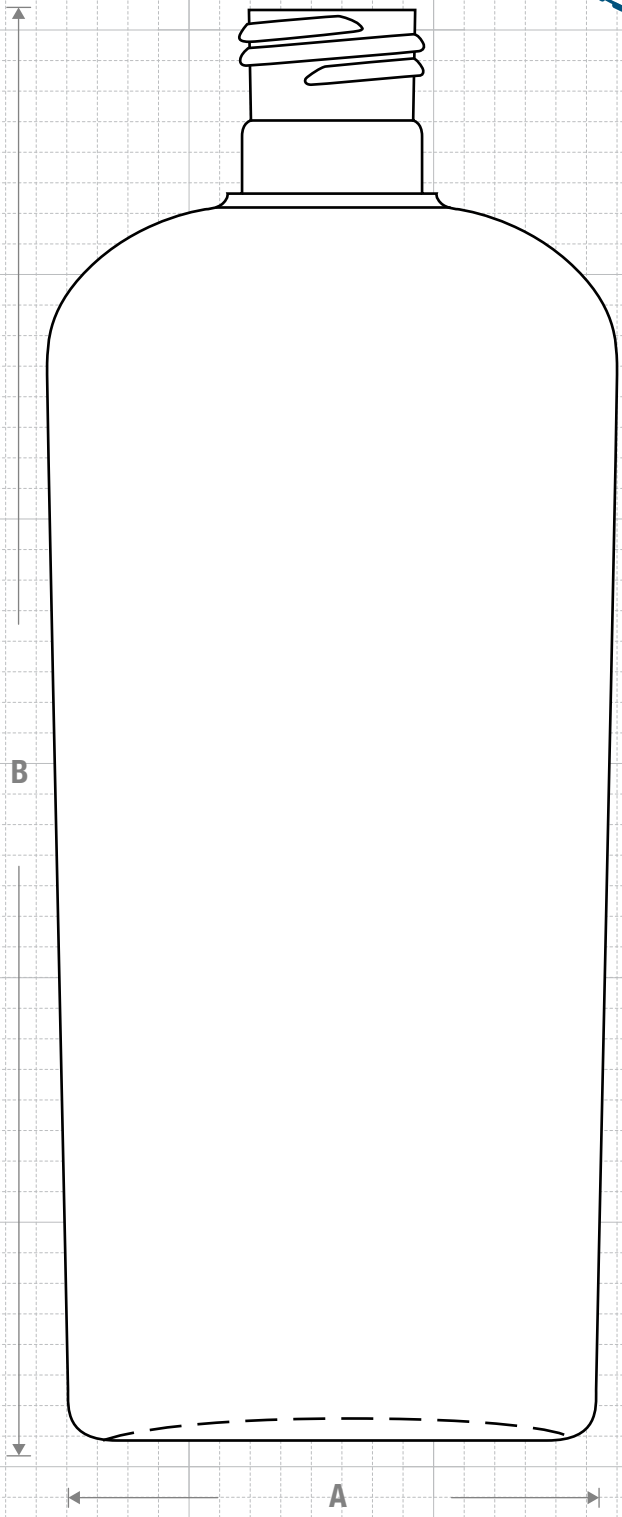

FRONT VIEW



SIDE VIEW

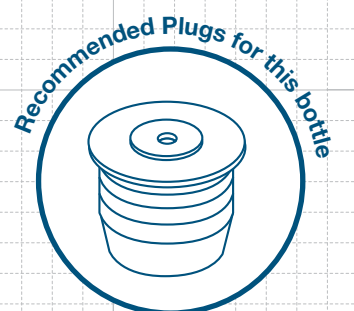
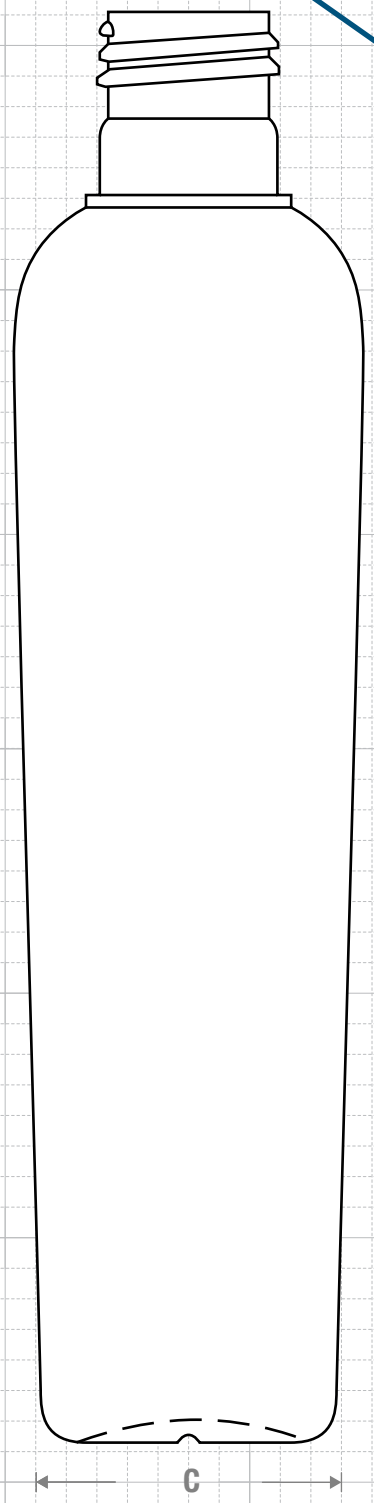

FRICTION FIT

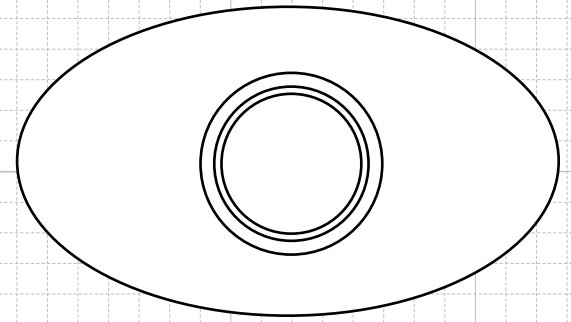

TOP VIEW

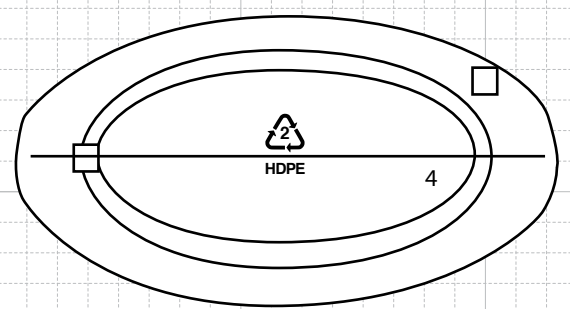

BOTTOM VIEW



CLASSIC CONTAINERS INC
 1700 S. Hellman Ave.
 Ontario, CA 91761
 Phone: 909-930-3610
 e-mail: info@classiccontainers.com
 www.classiccontainers.com

Drawing: 12 oz Classic Oval 24/415	Gram Weight: 29 ± 2	Max Print Area (Height): 5.000"	Cases Per Pallet: 16
Stock Code: 001200230250000	Neck Finish: 24/415	Max Print Area (Width): 2.250"	Box Dimensions: 24 7/16 x 18 1/2 x 23
Manufacturing Process: Extrusion Blow Molding	Base Width (A): Base Deep (C) 2.820 ± 0.050 1.640 ± 0.050	Case Pack: 270	Stock Material:
Overflow Capacity: 384 - 401 ml (13.0 - 13.6 oz)	Overall Height (B): 7.420 ± 0.050	Case Weight (lb): 20.1 ± 1.2	Rev #3 - 06/2016 Drawing not exactly to size.

