

FRONT VIEW

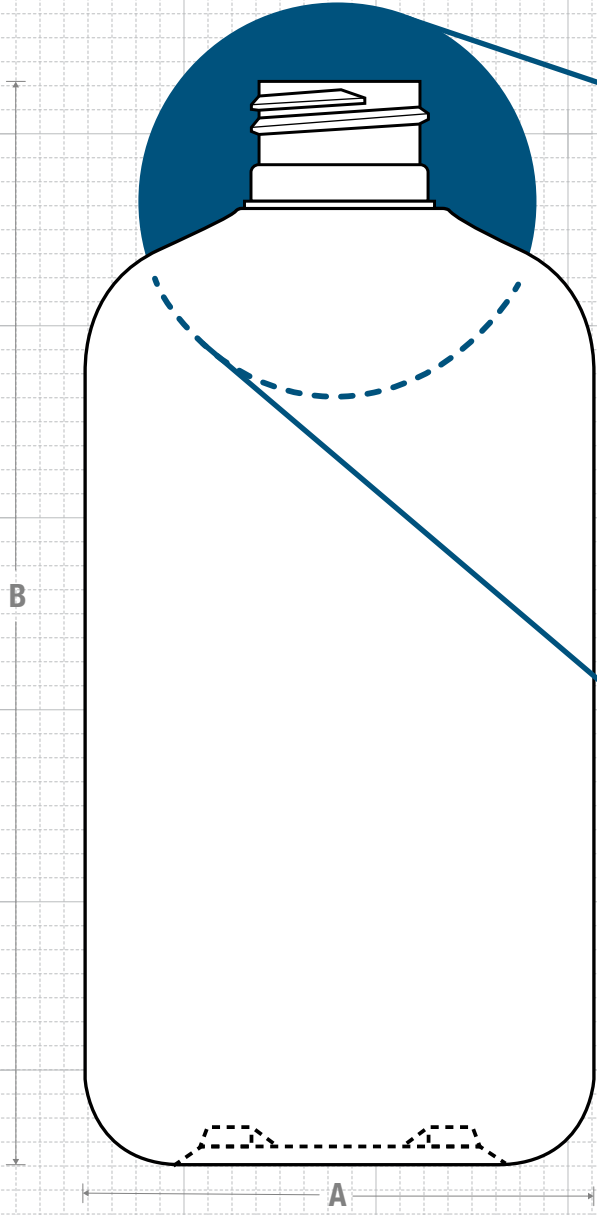

NECK & THREAD DETAIL

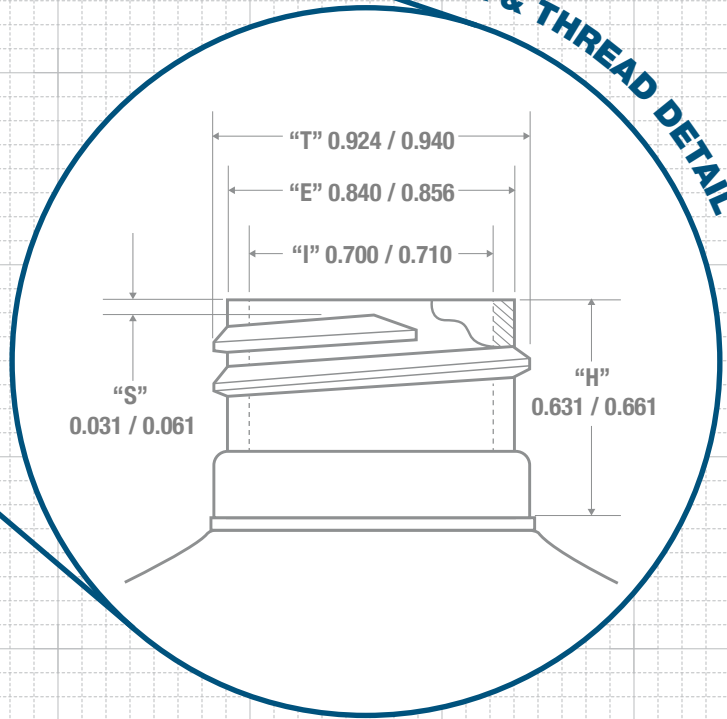

BOTTOM VIEW

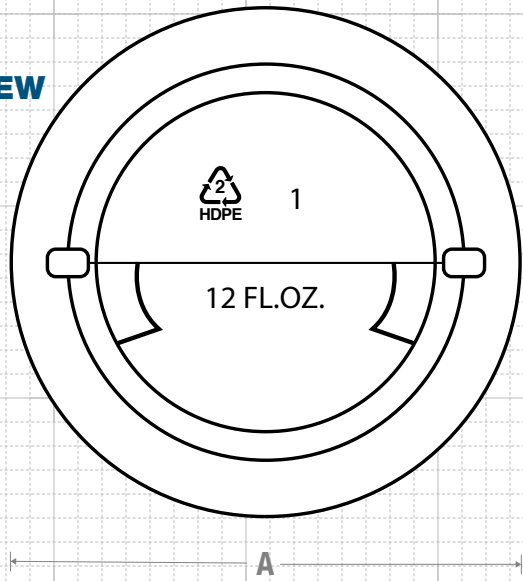

Recommended Plugs for this bottle



FRICITION FIT



CLASSIC CONTAINERS INC
 1700 S. Hellman Ave.
 Ontario, CA 91761
 Phone: 909-930-3610
 e-mail: info@classiccontainers.com
 www.classiccontainers.com

Drawing: 12 oz Boston Round 24/410	Gram Weight: 28 ± 2	Max Print Area (Height): 3.438"	Cases Per Pallet: 16
Stock Code: 0001200060240000	Neck Finish: 24/410	Max Print Area (Width): 8.125"	Box Dimensions: 24 7/16 x 18 1/2 x 23
Manufacturing Process: Extrusion Blow Molding	Base Width (A): 2.650 ± 0.050	Case Pack: 272	Stock Material:
Overflow Capacity: 380 - 402 ml (12.9 - 13.6 oz)	Overall Height (B): 5.648 ± 0.050	Case Weight (lb): 19.7 ± 1.2	Rev #5 - 12/2021 Drawing not exactly to size.

PRINTING SPECIFICATIONS: 12 oz BOSTON ROUND

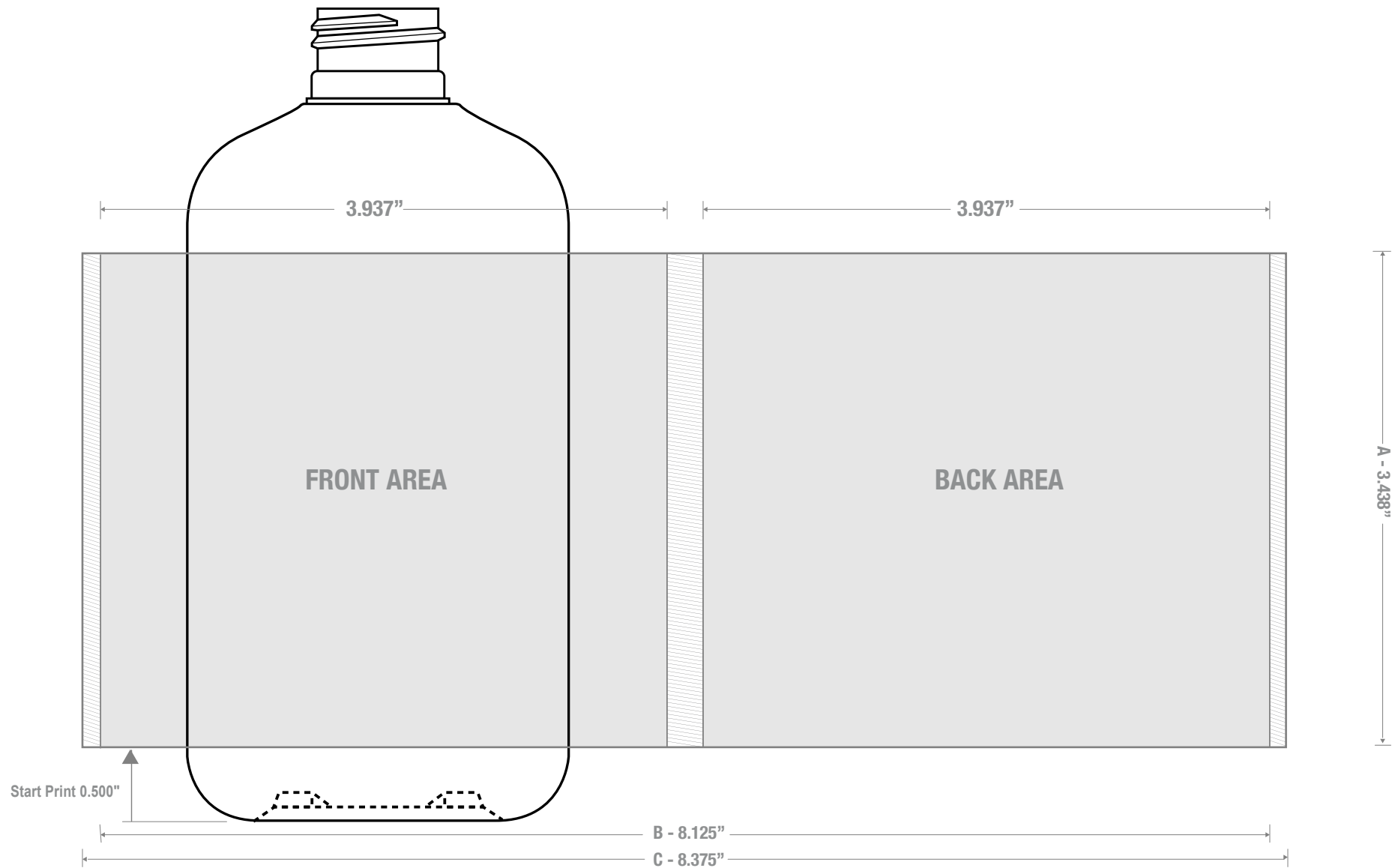

1700 S Hellman Ave, Ontario, California 91761
Phone: (909) 930-3610 | Fax: (909) 930-3640
e-mail: info@classiccontainers.com
www.classiccontainers.com

A - Total Height.
B - Max. Decorating Area.
C - Total bottle circumference.
▨ - Unprintable area.

LABELING SPECIFICATIONS: 12 oz BOSTON ROUND

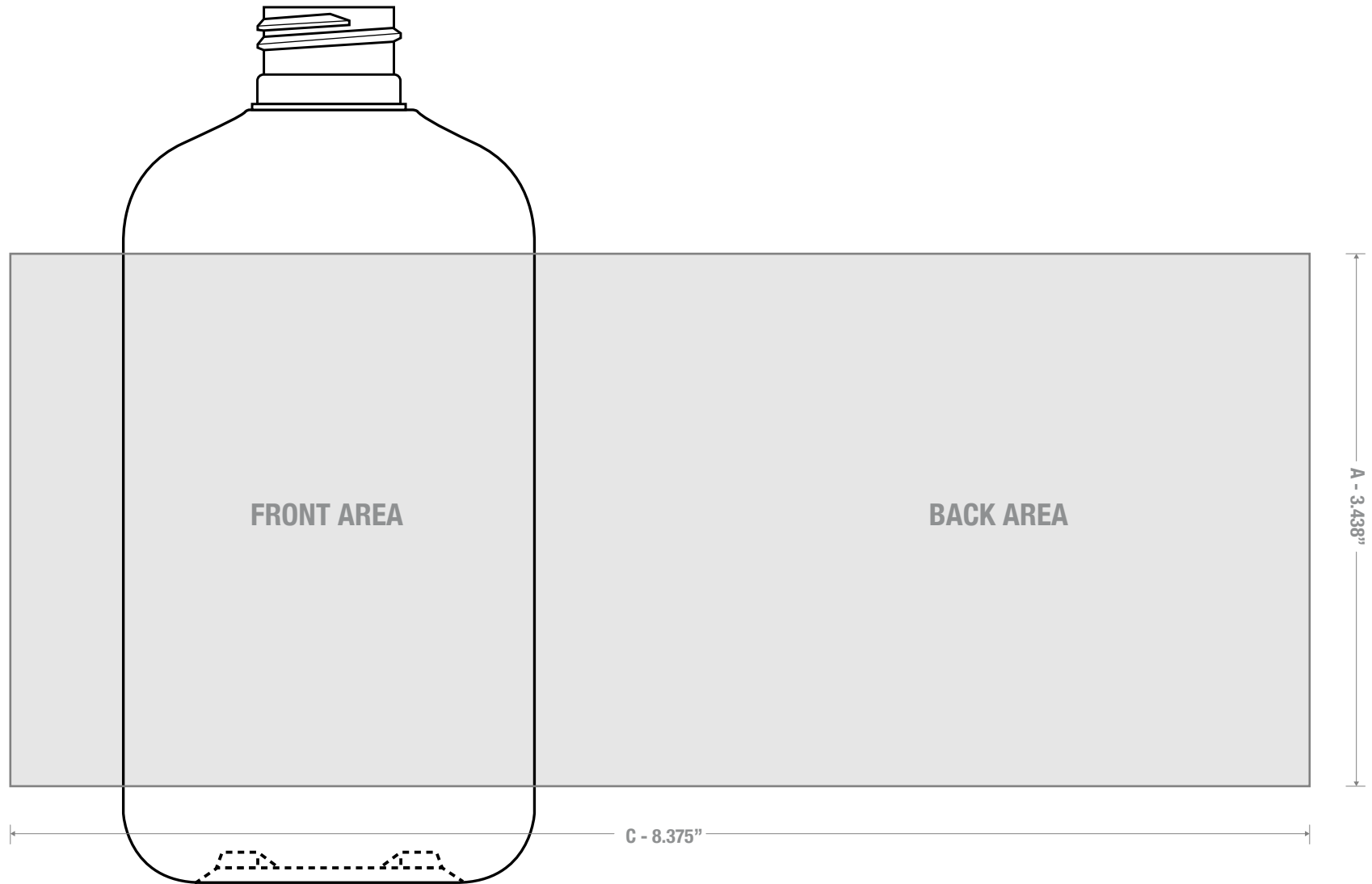

1700 S Hellman Ave, Ontario, California 91761
Phone: (909) 930-3610 | Fax: (909) 930-3640
e-mail: info@classiccontainers.com
www.classiccontainers.com

A - Total Height.
B - Max. Decorating Area.