

**FRONT VIEW**

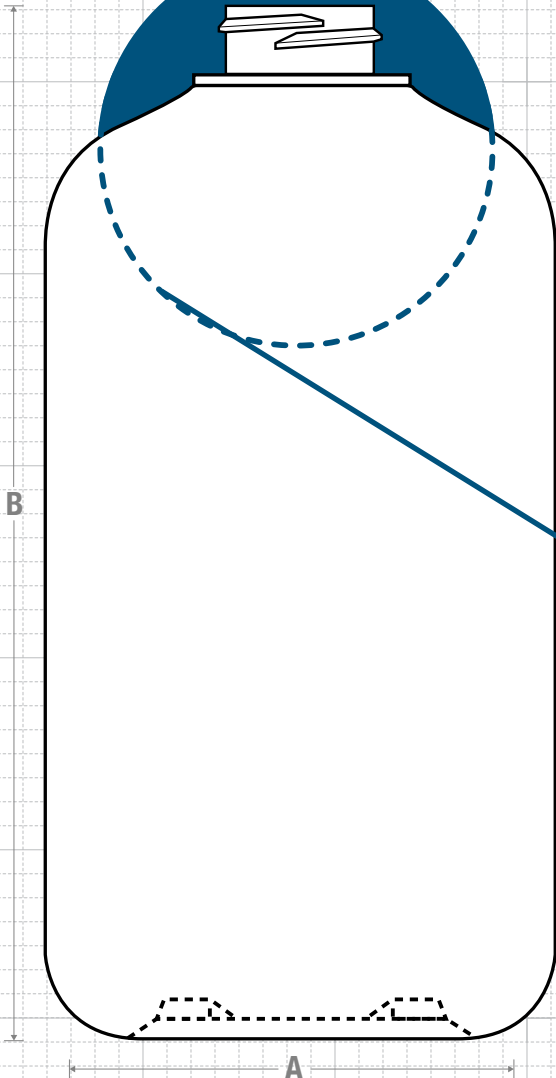

**NECK & THREAD DETAIL**

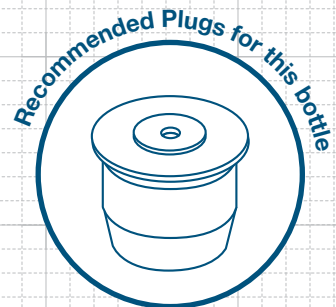
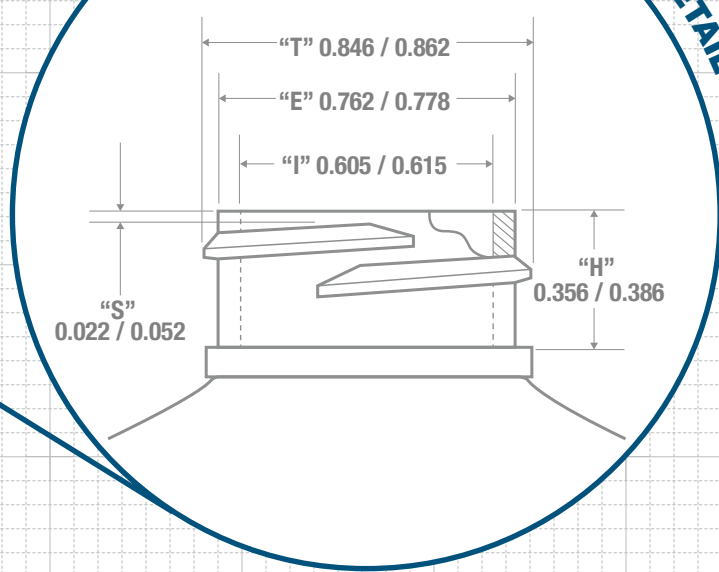

**FRICTION FIT**

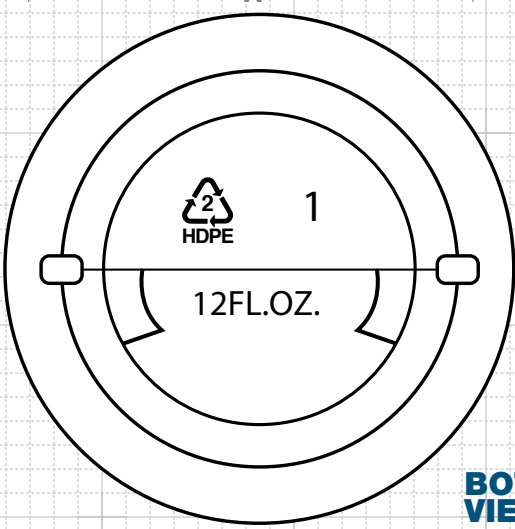

**BOTTOM VIEW**

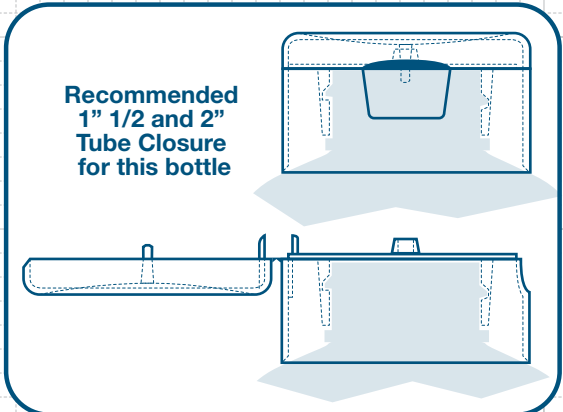

**CLASSIC CONTAINERS INC**  
 1700 S. Hellman Ave.  
 Ontario, CA 91761  
 Phone: 909-930-3610  
 e-mail: info@classiccontainers.com  
 www.classiccontainers.com

Drawing: <b>12 oz Boston Round 22/400</b>	Gram Weight: <b>28 ± 2</b>	Max Print Area (Height): <b>3.438"</b>	Cases Per Pallet: <b>16</b>
Stock Code: <b>001200060220000</b>	Neck Finish: <b>22/400</b>	Max Print Area (Width): <b>8.125"</b>	Box Dimensions: <b>24 7/16 x 18 1/2 x 23</b>
Manufacturing Process: <b>Extrusion Blow Molding</b>	Base Width (A): <b>2.650 ± 0.050</b>	Case Pack: <b>272</b>	Stock Material:
Overflow Capacity: <b>380 - 402 ml (12.9 - 13.6 oz)</b>	Overall Height (B): <b>5.380 ± 0.050</b>	Case Weight (lb): <b>19.7 ± 1.2</b>	Rev #5 - 12/2021 Drawing not exactly to size.

# PRINTING SPECIFICATIONS: 12 oz BOSTON ROUND

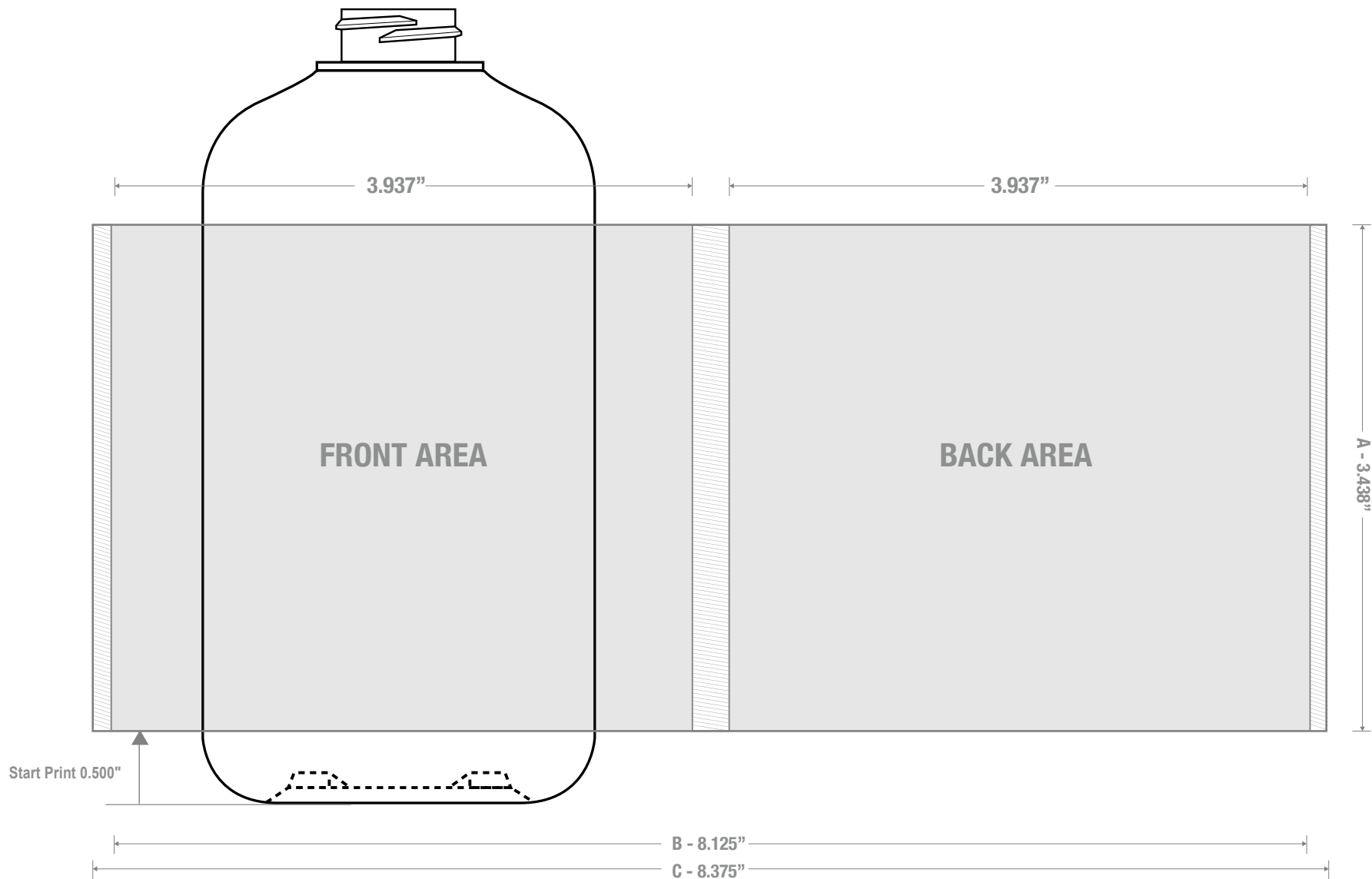

**LASSIC  
CONTAINERS  
Inc.**

1700 S Hellman Ave, Ontario, California 91761  
Phone: (909) 930-3610 | Fax: (909) 930-3640  
e-mail: [info@classiccontainers.com](mailto:info@classiccontainers.com)  
[www.classiccontainers.com](http://www.classiccontainers.com)

**A - Total Height.**  
**B - Max. Decorating Area.**  
**C - Total bottle circumference.**  
☒ - Unprintable area.

# LABELING SPECIFICATIONS: 12 oz BOSTON ROUND

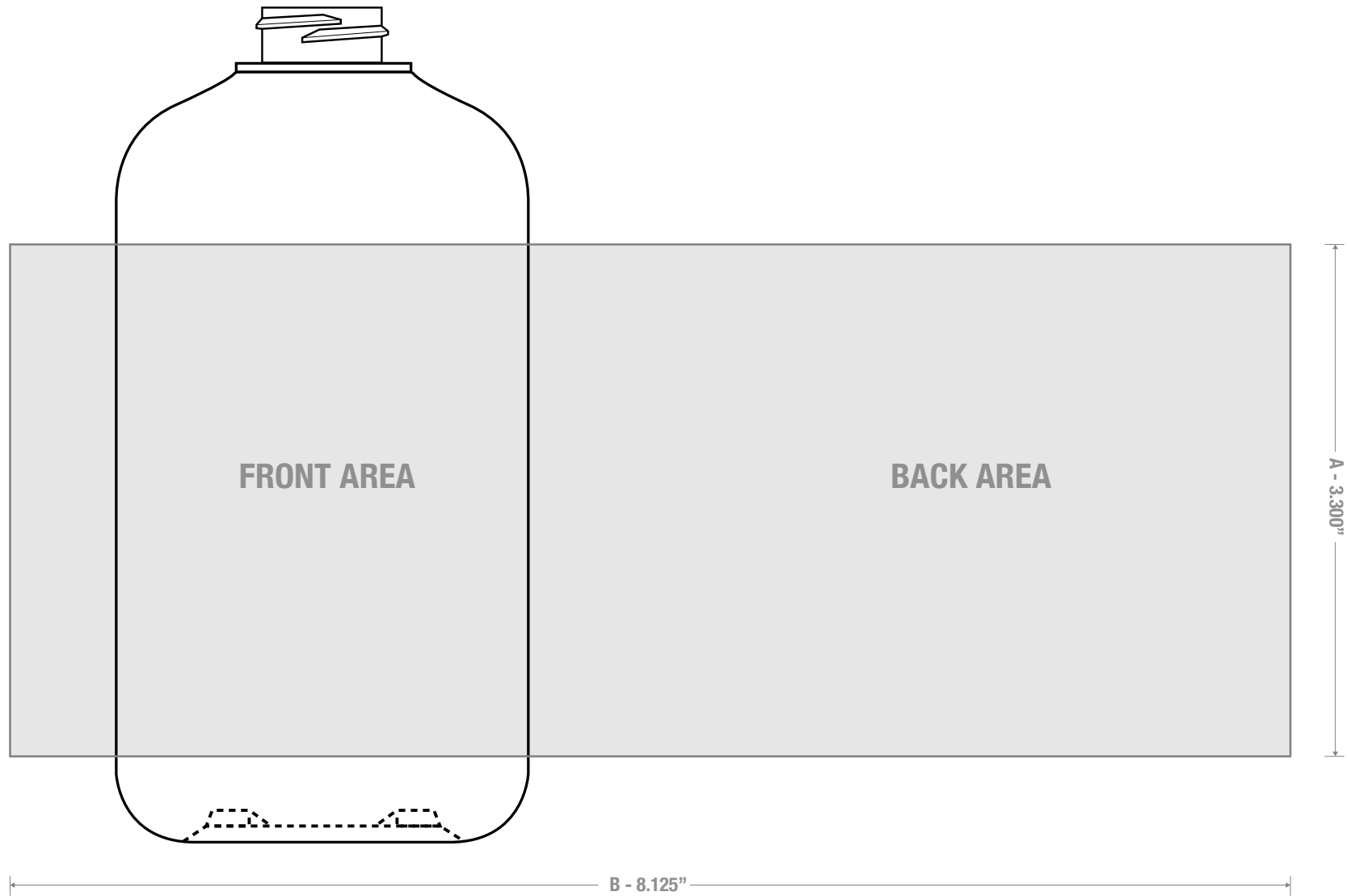

**LASSIC  
CONTAINERS  
Inc.**

1700 S Hellman Ave, Ontario, California 91761  
Phone: (909) 930-3610 | Fax: (909) 930-3640  
e-mail: [info@classiccontainers.com](mailto:info@classiccontainers.com)  
[www.classiccontainers.com](http://www.classiccontainers.com)

**A - Total Height.**  
**B - Max. Decorating Area.**