

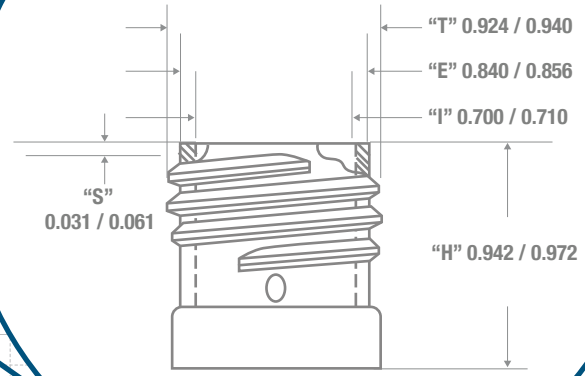

NECK & THREAD DETAIL

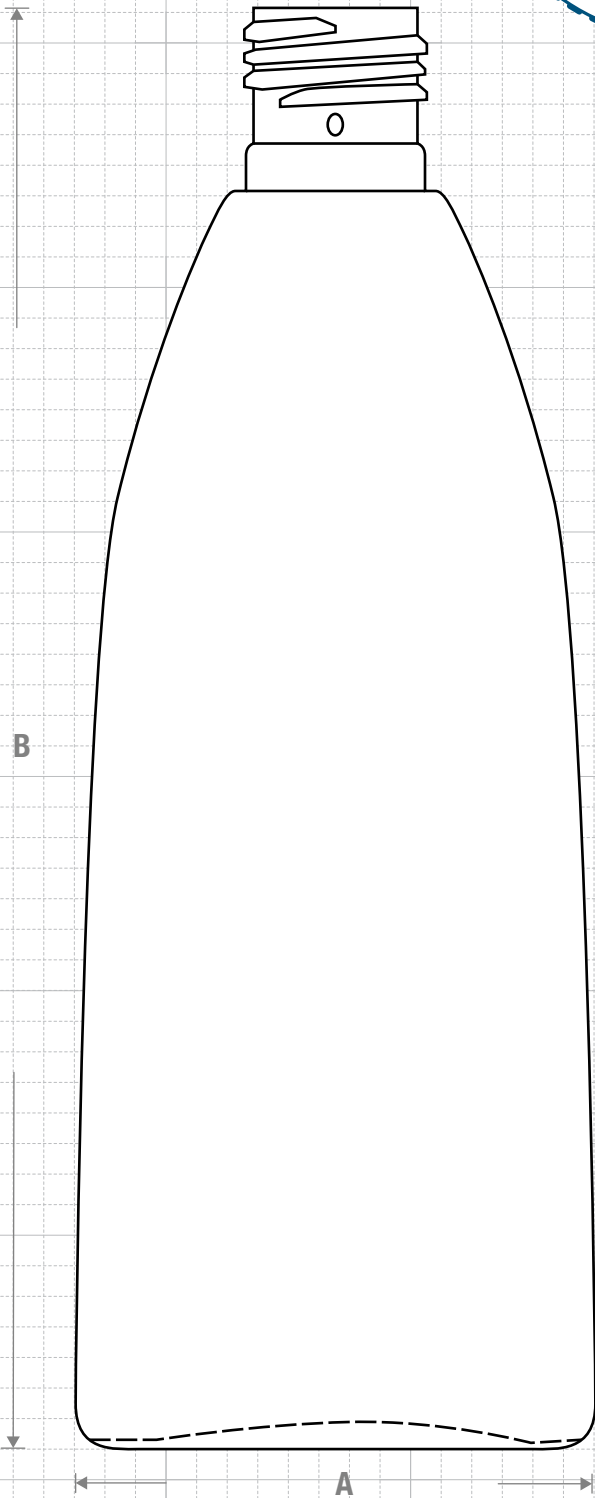

FRONT VIEW



SIDE VIEW

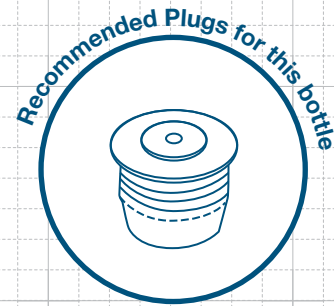
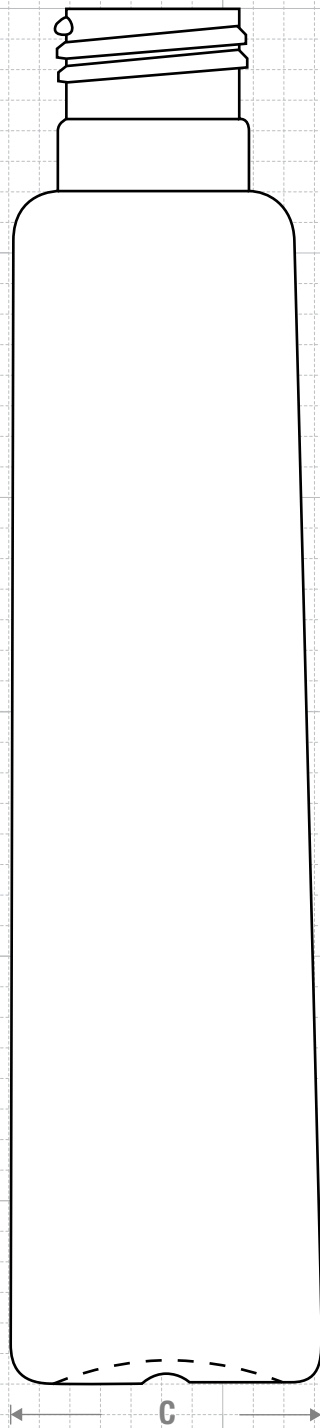

FRICITION FIT

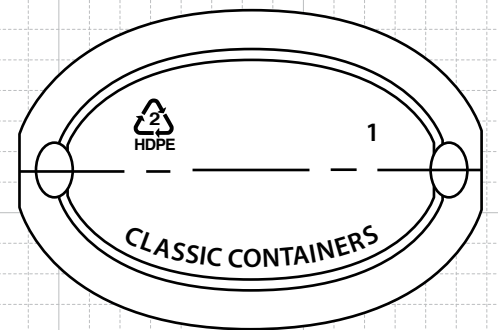

BOTTOM VIEW



CLASSIC CONTAINERS INC
 1700 S. Hellman Ave.
 Ontario, CA 91761
 Phone: 909-930-3610
 e-mail: info@classiccontainers.com
 www.classiccontainers.com

Drawing:
10 oz Teardrop 24/415

Gram Weight:
28.5 ± 2

Max Print Area (Height):
5.000"

Cases Per Pallet: **16**

Stock Code:
001000350250000

Neck Finish:
24/415

Max Print Area (Width):
 Shoulder: **0.850"** Base: **1.750"**

Box Dimensions:
24 7/16 x 18 1/2 x 23

Manufacturing Process:
Extrusion Blow Molding

Base Width (A) Base Deep (C):
2.614± 0.050 1.700± 0.050

Case Pack: **333**

Stock Material:



Overflow Capacity:
303 - 321 ml (10.3 - 10.9 oz)

Overall Height (B):
7.500 ± 0.050

Case Weight (lb): **23.8 ± 1.5**

Rev #3 06/2016

Drawing not exactly to size.

FRONT

BACK

