



Drawing:
1/4 oz Boston Round 15/415

Stock Code:
014F00060150000

Manufacturing Process:
Injection Blow Molding

Overflow Capacity:
8.9 - 10 ml (0.30 - 0.34 oz)

Gram Weight:
3.2 ± 0.5

Neck Finish:
15/415

Base Width (A):
0.885 ± 0.050

Overall Height (B):
1.800 ± 0.050

Max Print Area (Height):
0.750"

Max Print Area (Width):
2.563"

Case Pack: 4200

Case Weight (lb): 31.5 ± 4.6

Cases Per Pallet: 20

Box Dimensions:
23 5/8 x 15 9/16 x 17

Stock Material:



FRONT VIEW

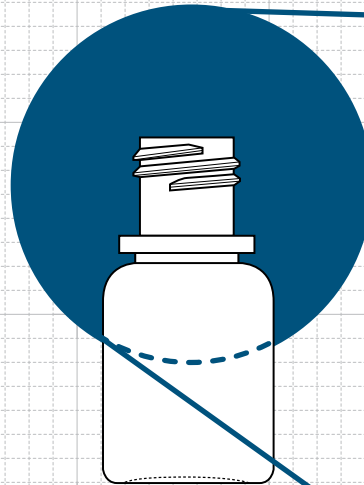
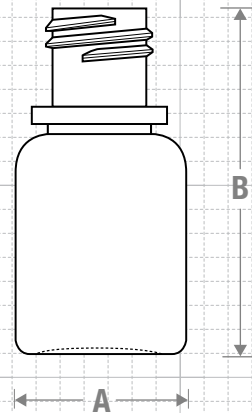

THREAD DETAIL

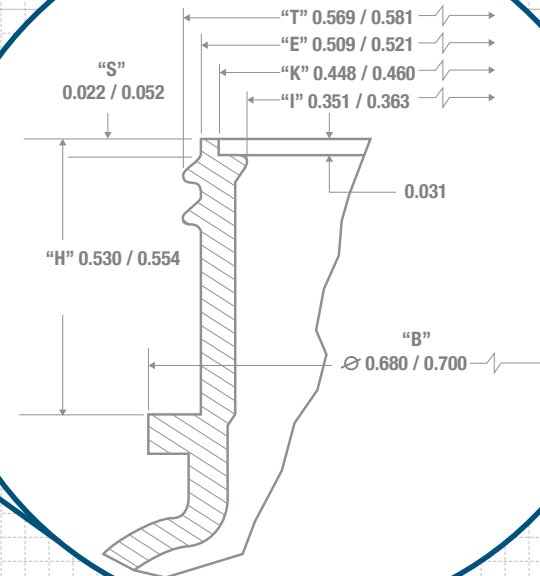

BOTTOM VIEW

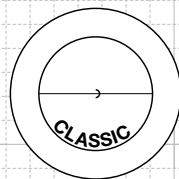

Recommended Cap for this bottle



DROPPER TIP CAP

Recommended Plugs for this bottle



SNAP FIT

CLASSIC CONTAINERS INC
1700 S. Hellman Ave.
Ontario, CA 91761
Phone: 909-930-3610
e-mail: info@classiccontainers.com
www.classiccontainers.com

PRINTING SPECIFICATIONS: 1/4 oz BOSTON ROUND

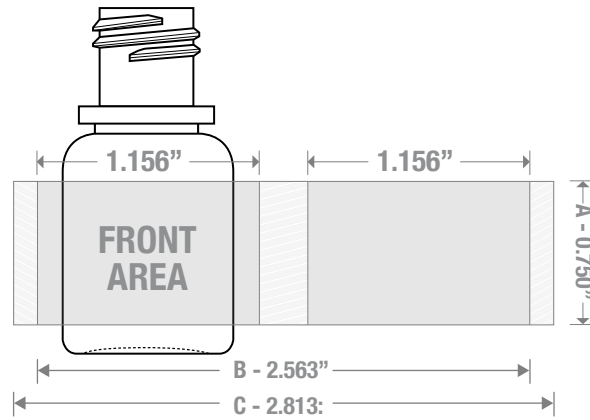

1700 S Hellman Ave, Ontario, California 91761
Phone: (909) 930-3610 | Fax: (909) 930-3640
e-mail: info@classiccontainers.com
www.classiccontainers.com

A - Total Height.
B - Max. Decorating Area.
C - Total bottle circumference.
▨ - Unprintable area.